

JVC

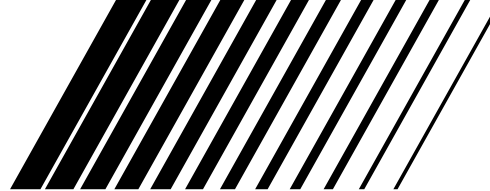

MICRO COMPONENT SYSTEM

微型组合音响

UX-L40— Consists of **CA-UXL40** and **SP-UXL40**
由 **CA-UXL40** 及 **SP-UXL40** 组成

UX-L30— Consists of **CA-UXL30** and **SP-UXL30**
由 **CA-UXL30** 及 **SP-UXL30** 组成

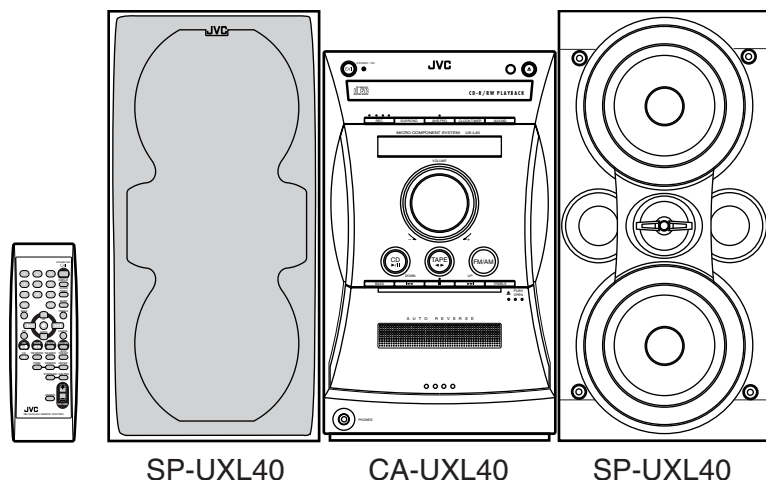

SP-UXL40

CA-UXL40

SP-UXL40

COMPACT
disc
DIGITAL AUDIO

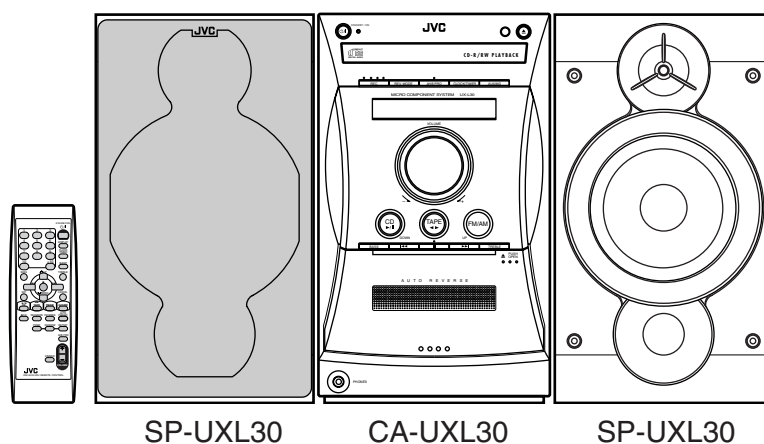

SP-UXL30

CA-UXL30

SP-UXL30

INSTRUCTIONS

使用说明书

For Customer Use:

Enter below the Model No. and Serial No. which are located either on the rear, bottom or side of the cabinet. Retain this information for future reference.

Model No. _____

Serial No. _____

GVT0080-003A
[US, UJ]

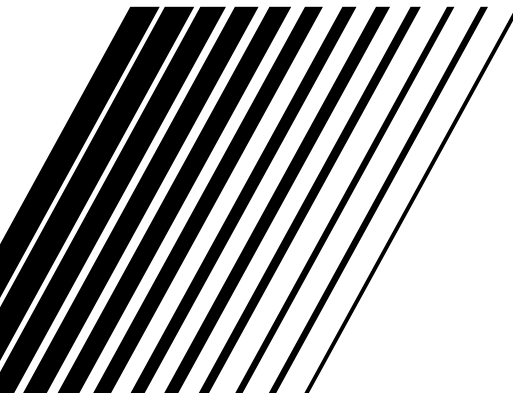

Warnings, Cautions and Others

警告，注意及其他须知事项

CAUTION—STANDBY/ON button!

Disconnect the mains plug to shut the power off completely (the STANDBY/ON lamp goes off). The STANDBY/ON  button in any position does not disconnect the mains line.

- When the unit is on standby, the STANDBY/ON lamp lights red.
- When the unit is turned on, the STANDBY/ON lamp lights green.

The power can be remote controlled.

注意— STANDBY/ON 开关！

无论 STANDBY/ON  开关在任何位置，电源线的电源还是没有被切断，若要将电源完全关闭，应把电源插头脱离插座（STANDBY/ON 灯熄灭）。

- 当主机正处于备用状态，STANDBY/ON 灯为红色。
- 当主机开启后，STANDBY/ON 灯为青色。

电源开关可用遥控器控制。

CAUTION

To reduce the risk of electrical shocks, fire, etc.:

1. Do not remove screws, covers or cabinet.
2. Do not expose this appliance to rain or moisture.

注意

为了减低触电，火灾等危险：

1. 请勿擅自卸下螺丝钉，盖子或机壳。
2. 切勿让本机受雨淋或置潮湿环境中。

CAUTION

- Do not block the ventilation openings or holes. (If the ventilation openings or holes are blocked by a newspaper or cloth, etc., the heat may not be able to get out.)
- Do not place any naked flame sources, such as lighted candles, on the apparatus.
- When discarding batteries, environmental problems must be considered and local rules or laws governing the disposal of these batteries must be followed strictly.
- Do not expose this apparatus to rain, moisture, dripping or splashing and that no objects filled with liquids, such as vases, shall be placed on the apparatus.

注意

- 请勿堵塞通风口或通风孔。
(如果通风口或通风孔被报纸或布等堵塞，热量将无法散出。)
- 请勿在本设备上放置任何裸露的火源，如点燃的蜡烛。
- 处理废弃电池时，必须考虑环境问题，并严格遵守当地关于处理废弃电池的有关法律或规定。
- 切勿将本装置暴露于雨水所及、潮湿、滴水或易于溅起水花的地方，亦不要将任何装满液体的物件（如花瓶）放置在本装置上。

IMPORTANT FOR LASER PRODUCTS/ 雷射产品的重要说明

REPRODUCTION OF LABELS/ 标签内容说明

① CLASSIFICATION LABEL, PLACED ON EXTERIOR SURFACE

① 分类标签，贴在机壳背后

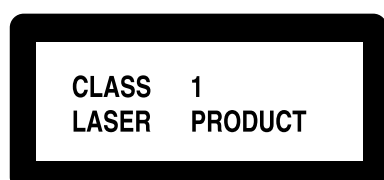

② WARNING LABEL, PLACED INSIDE THE UNIT

② 警告标签，贴于机内

CAUTION: Invisible laser radiation when open and interlock failed or defeated. AVOID DIRECT EXPOSURE TO BEAM. (e)	ADVARSEL: Usynlig laserstråling ved åbning, når sikkerhedsafbrydere er ude af funktion. Undgå udsættelse for stråling. (d)	WARNING: Osynlig laserstråling när denna del är öppnad och spärren är urkopplad. Betrakta ej strålen. (s)	VARO: Avattaessa ja suojalukitus ohitettaessa olet altiina näkymättömälle lasersäteilylle. Älä katso säteeseen. (f)
--	---	--	--

1. CLASS 1 LASER PRODUCT

2. **CAUTION:** Invisible laser radiation when open and interlock failed or defeated. Avoid direct exposure to beam.

3. **CAUTION:** Do not open the top cover. There are no user serviceable parts inside the Unit; leave all servicing to qualified service personnel.

1. 一级雷射产品

2. **注意：**当内部锁定装置失效或者损坏后，打开盖板可能会产生不可见的雷射幅射。应避免受到光束直接照射。

3. **注意：**请勿打开顶盖板。本机内部没有用户可自行维修的部件；所有维修工作应由有资格的人员完成。

CAUTION: Proper Ventilation

To avoid risk of electric shock and fire, and to prevent damage, locate the apparatus as follows:

1 Front:

No obstructions and open spacing.

2 Sides/ Top/ Back:

No obstructions should be placed in the areas shown by the dimensions below.

3 Bottom:

Place on the level surface. Maintain an adequate air path for ventilation by placing on a stand with a height of 10 cm or more.

注意：正确通风

为免发生触电和火警的危险，及防止本机受损，请将本机如下放置：

1. 前面： 没有障碍物及地方开阔。

2. 侧面/顶面/背面： 在图中所示范围中，不应放置任何障碍物。

3. 底部： 放置在水平面上。放置在一个高 10 厘米或以上的台上，以保持足够的通风道。

Front view

正面

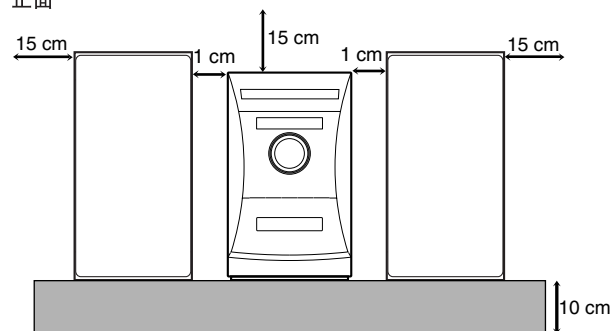

UX-L40/UX-L30

Side view

侧面

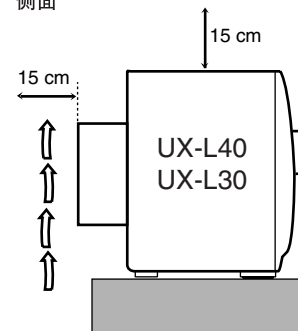

Introduction

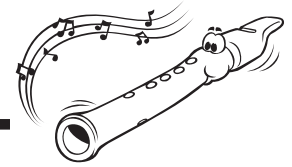

We would like to thank you for purchasing one of our JVC products. Before operating this unit, read this manual carefully and thoroughly to obtain the best possible performance from your unit, and retain this manual for future reference.

About This Manual

This manual is organized as follows:

- **The manual mainly explains operations using the buttons on the remote control.**
You can use the buttons both on the remote control and on the unit for the same operations if they have the same or similar names (or marks), unless mentioned otherwise.
- Basic and common information that is the same for many functions is grouped in one place, and is not repeated in each procedure. For instance, we do not repeat the information about turning on/off the unit, setting the volume, changing the sound effects, and others, which are explained in the section “Common Operations” on pages 9 and 11.
- The following marks are used in this manual:



Gives you warnings and cautions to prevent from damage or risk of fire/electric shock. Also gives you information which is not good for obtaining the best possible performance from the unit.



Gives you information and hints you had better know.

The illustrations used in this manual are of UX-L40 unless mentioned otherwise.

Precautions

Installation

- Install in a place which is level, dry and neither too hot nor too cold—between 5°C and 35°C.
- Install the unit in a location with adequate ventilation to prevent internal heat built-up in the unit.
- Leave sufficient distance between the unit and the TV.
- Keep the speakers away from the TV to avoid interference with TV.



DO NOT install the unit in a location near heat sources, or in a place subject to direct sunlight, excessive dust or vibration.

Power sources

- When unplugging from the wall outlet, always pull the plug, not the AC power cord.



DO NOT handle the AC power cord with wet hands.

Moisture condensation

Moisture may condense on the lens inside the unit in the following cases:

- After starting heating in the room
 - In a damp room
 - If the unit is brought directly from a cold to a warm place
- Should this occur, the unit may malfunction. In this case, leave the unit turned on for a few hours until the moisture evaporates, unplug the AC power cord, and then plug it in again.

Others

- Should any metallic object or liquid fall into the unit, unplug the unit and consult your dealer before operating any further.
- If you are not going to operate the unit for an extended period of time, unplug the AC power cord from the wall outlet.



DO NOT disassemble the unit since there are no user serviceable parts inside.

If anything goes wrong, unplug the AC power cord and consult your dealer.

Contents

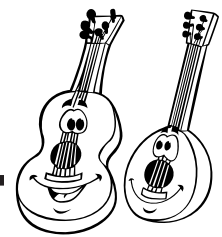

Location of the Buttons and Controls	3	Playing Back CDs (CD/CD-R/CD-RW)	14
Remote Control	3	Playing Back the Entire CD—Normal Play	14
Front Panel	4	Basic CD Operations	14
Getting Started	6	Programming the Playing Order of the Tracks	
Supplied Accessories	6	—Program Play	15
Putting the Batteries into the Remote Control	6	Playing at Random—Random Play	16
Connecting Antennas	6	Repeating Tracks—Repeat Play	16
Connecting Speakers	7	Prohibiting Disc Ejection—Tray Lock	16
Connecting Other Equipment	8	Playing Back Tapes	17
Adjusting the Voltage Selector	8	Playing Back a Tape	17
Common Operations	9	Recording	18
Setting the Clock	9	Recording on a Tape	18
Setting the AM Tuner Interval Spacing	9	CD Direct Recording	19
Turning On the Power	10	One Track Recording	19
Selecting the Sources and Starting Play	10	Using the Timers	20
Adjusting the Volume	10	Using Daily Timer and Recording Timer	20
Adjusting the Tone (Bass/Treble)	11	Using Sleep Timer	21
Reinforcing the Bass Sound	11	Troubleshooting	22
Reinforcing the Surround Effect		Maintenance	23
(ONLY FOR UX-L40)	11	Specifications	24
Selecting the Illumination Brightness	11		
Listening to FM and AM Broadcasts	12		
Tuning in to a Station	12		
Presetting Stations	12		
Tuning in to a Preset Station	13		

Location of the Buttons and Controls

Become familiar with the buttons and controls on your unit.

Remote Control

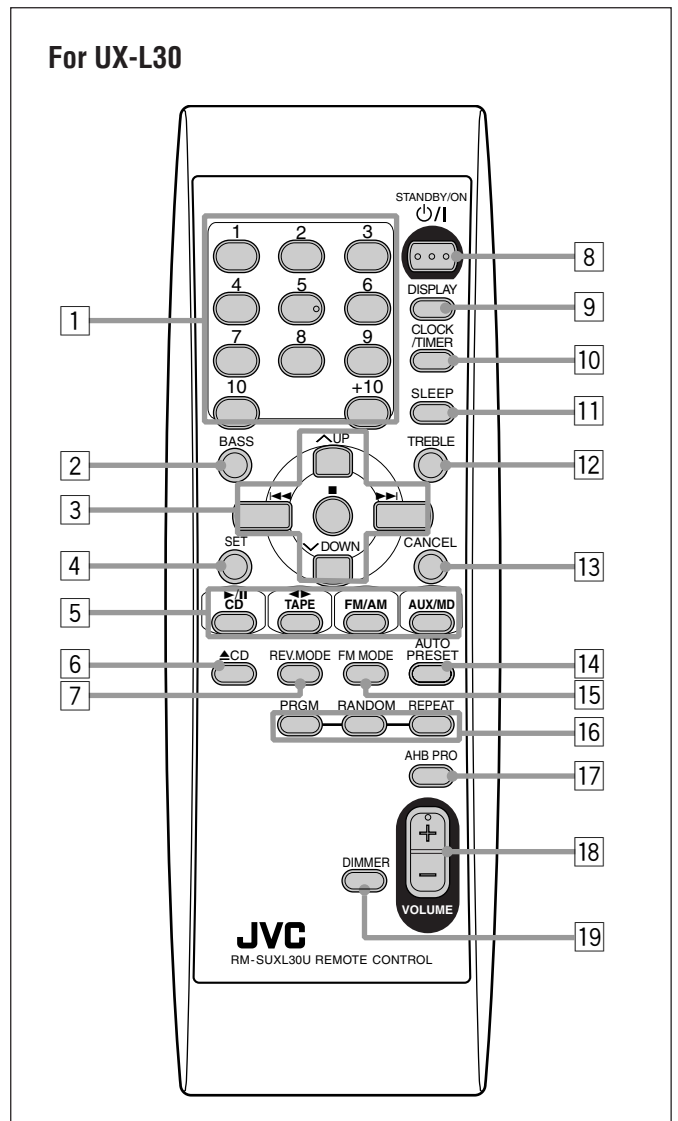
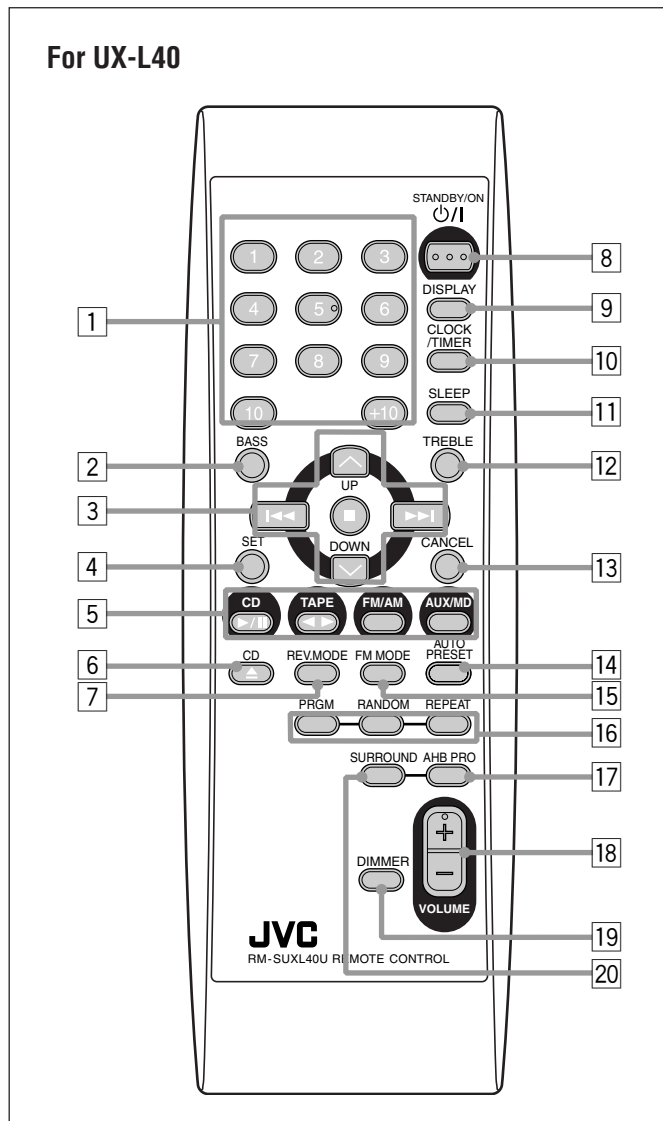

See pages in the parentheses for details.

Remote Control

- 1 Number buttons
- 2 BASS button (11)
- 3 Multi operation buttons
 - UP, ◀◀ (reverse skip), ■ (stop), ▶▶ (forward skip) and DOWN
- 4 SET button (13, 15)
- 5 Source buttons
 - CD ▶/||, TAPE ◀▶, FM/AM and AUX/MD
 Pressing one of these buttons also turns on the unit.
- 6 ▲ CD (disc tray open/close) button (14)
Pressing this button also turns on the unit.
- 7 REV.MODE (reverse mode) button (17 – 19)

- 8 STANDBY/ON ⏻/| button (10, 21)
- 9 DISPLAY button (9)
- 10 CLOCK/TIMER button (9, 20, 21)
- 11 SLEEP button (21)
- 12 TREBLE button (11)
- 13 CANCEL button (15)
- 14 AUTO PRESET button (12)
- 15 FM MODE button (12)
- 16 CD play mode buttons (15, 16)
 - PRGM (program), RANDOM and REPEAT
- 17 AHB (Active Hyper Bass) PRO button (11)
- 18 VOLUME + / - button (10)
- 19 DIMMER button (11)
- 20 SURROUND button (ONLY FOR UX-L40) (11)

Front Panel

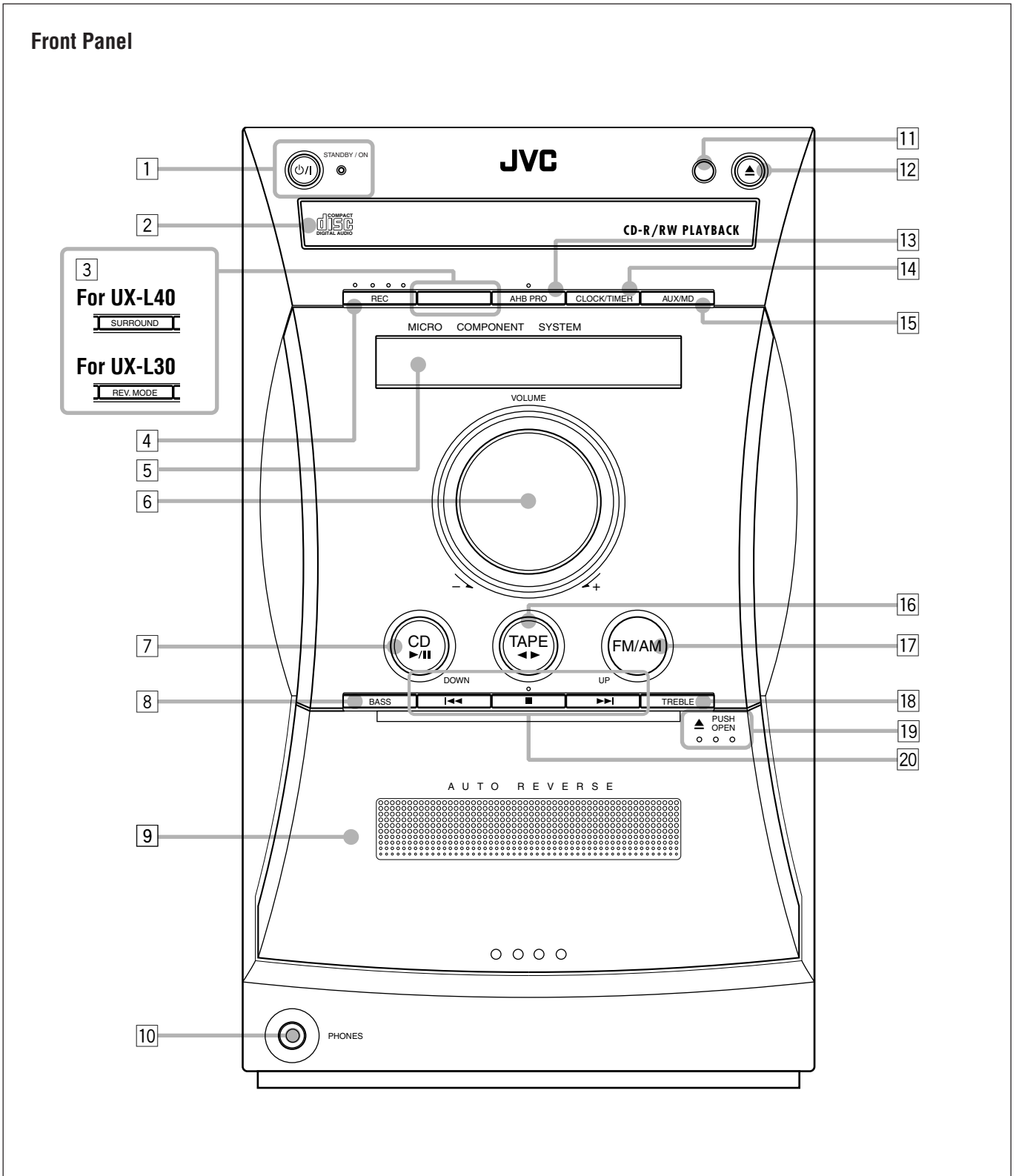

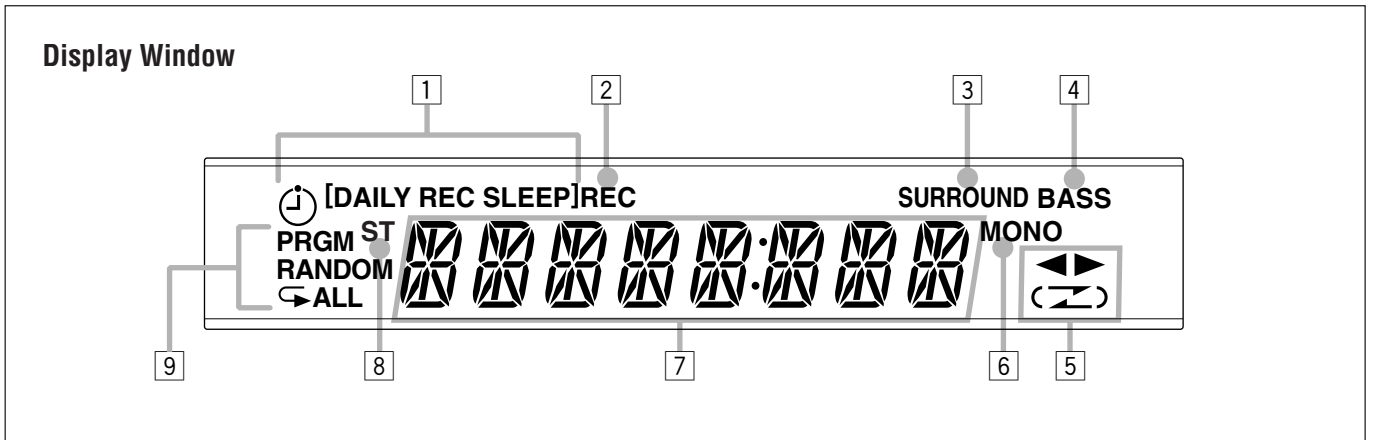

See pages in the parentheses for details.

Front Panel

- 1 STANDBY/ON button and STANDBY/ON lamp (9, 10, 16, 21)
- 2 Disc tray
- 3 For UX-L40: SURROUND button (11)
For UX-L30: REV.MODE (reverse mode) button (17 – 19)
- 4 REC (recording) button (18, 19)
- 5 Display window
- 6 VOLUME + / – control (10)
- 7 CD (play/pause) button (10, 14, 16, 19)
Pressing this button also turns on the unit.
- 8 BASS button (11)
- 9 Cassette holder
- 10 PHONES jack (10)
- 11 Remote sensor
- 12 (disc tray open/close) button (14)
Pressing this button also turns on the unit.
- 13 AHB (Active Hyper Bass) PRO button (11)
- 14 CLOCK/TIMER button (9, 20, 21)
- 15 AUX/MD button (10)
Pressing this button also turns on the unit.
- 16 TAPE (10, 17, 18)
Pressing this button also turns on the unit.
- 17 FM/AM button (10, 12, 13)
Pressing this button also turns on the unit.
- 18 TREBLE button (11)
- 19 PUSH OPEN (cassette holder open) portion (17 – 19)
- 20 Multi operation buttons
 - (reverse skip)/DOWN, (stop)
and (forward skip)/UP

Display Window

- 1 Timer indicators
 - (timer), DAILY, REC and SLEEP
- 2 REC (recording) indicator
- 3 SURROUND indicator (ONLY FOR UX-L40)
- 4 BASS indicator
- 5 Tape operation indicators
 - (tape direction) and (reverse mode)
- 6 MONO indicator
- 7 Main display
 - Shows the source name, frequency, etc.
- 8 ST (stereo) indicator
- 9 CD play mode indicators
 - PRGM (program), RANDOM and (repeat one/repeat all)

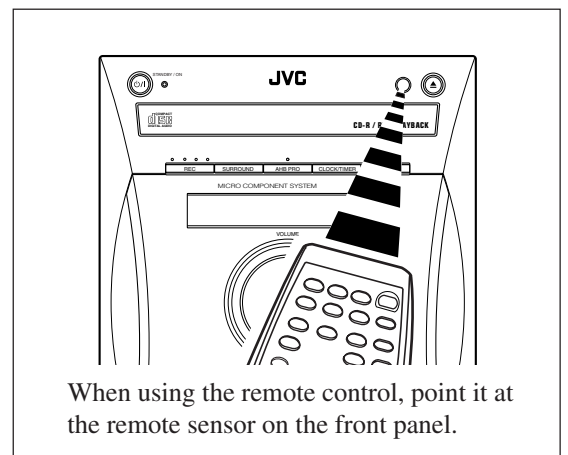

Supplied Accessories

Make sure that you have all the following items.
The number in the parentheses indicates the quantity of the pieces supplied.

- AM loop antenna (1)
- FM antenna (1)
- Remote control (1)
- Batteries (2)
- Speaker cords (2) (ONLY FOR UX-L40)
- AC plug adaptor (1)

If anything is missing, consult your dealer immediately.

Putting the Batteries into the Remote Control

Insert the batteries—R6(SUM-3)/AA(15F)—into the remote control, by matching the polarity (+ and –) on the batteries with the + and – markings on the battery compartment.

When the remote control can no longer operate the unit, replace both batteries at the same time.

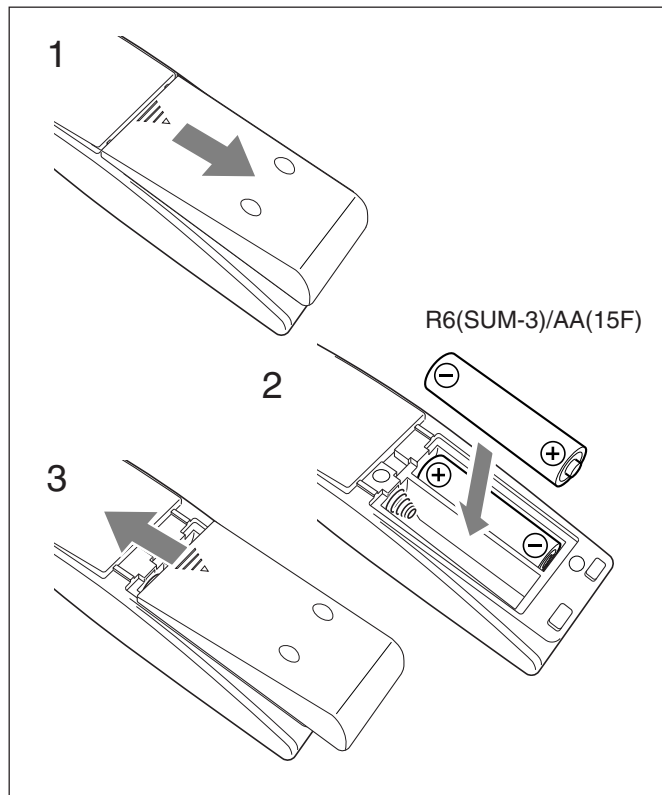

- DO NOT use an old battery together with a new one.
- DO NOT use different types of batteries together.
- DO NOT expose batteries to heat or flame.
- DO NOT leave the batteries in the battery compartment when you are not going to use the remote control for an extended period of time. Otherwise, it will be damaged from battery leakage.

Connecting Antennas

FM antenna

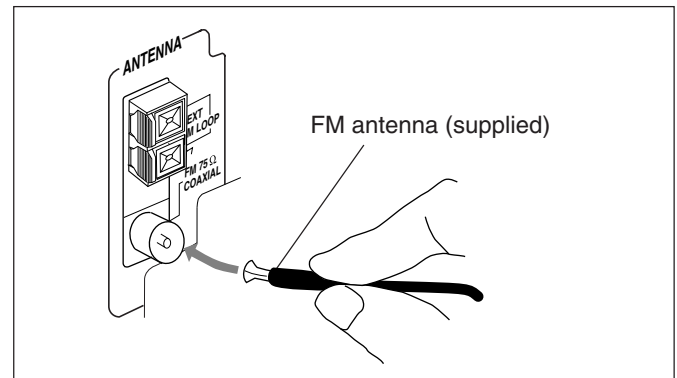

- 1 Attach the FM antenna to the FM 75 Ω COAXIAL terminal.
- 2 Extend the FM antenna.
- 3 Fasten it up in the position which gives you the best reception, then fix it on the wall, etc.



About the supplied FM antenna

The FM antenna supplied with this unit can be used as temporary measure. If reception is poor, you can connect an outdoor FM antenna.

To connect an outdoor FM antenna

Before connecting it, disconnect the supplied FM antenna.

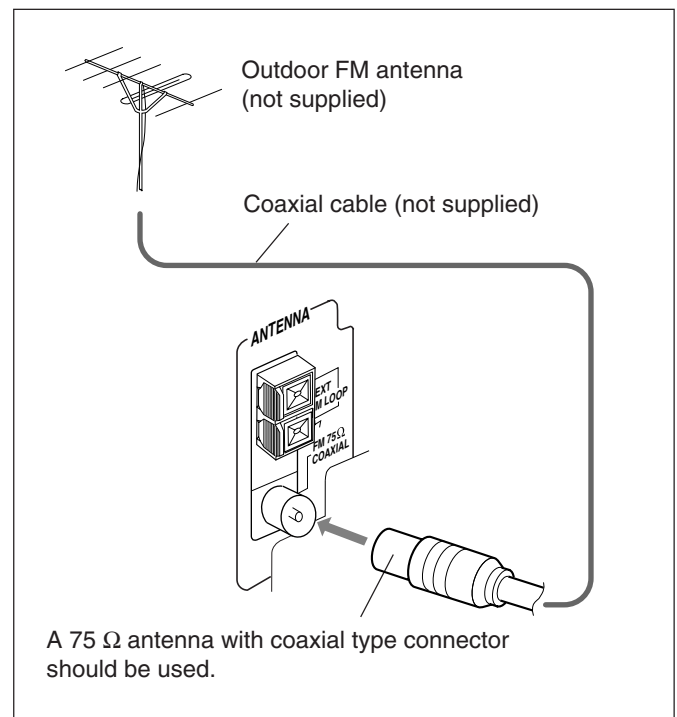

AM antenna

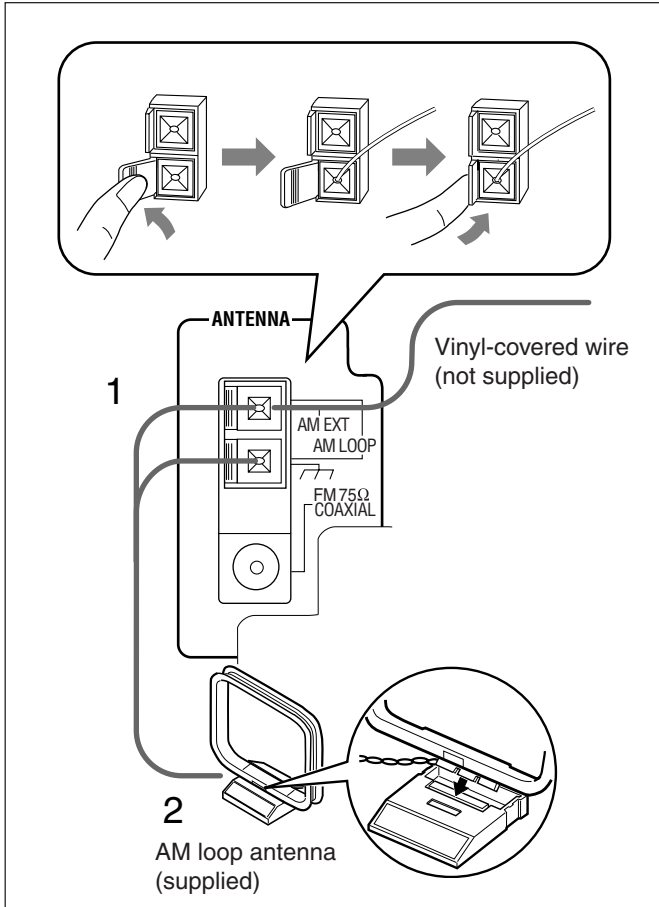

1 Connect the AM loop antenna to the AM LOOP terminals as illustrated.

- If cords are covered with insulation, twist the core of the cord at the end of each cord, then remove the insulation.

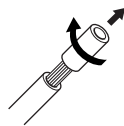

2 Turn the AM loop antenna until you have the best reception.

To connect an outdoor AM antenna

When reception is poor, connect a single vinyl-covered wire to the AM EXT terminal and extend it horizontally. (The AM loop antenna must remain connected.)



For better reception of both FM and AM

- Make sure the antenna conductors do not touch any other terminals and connecting cords.
- Keep the antennas away from metallic parts of the unit, connecting cords, and the AC power cord.

Connecting Speakers

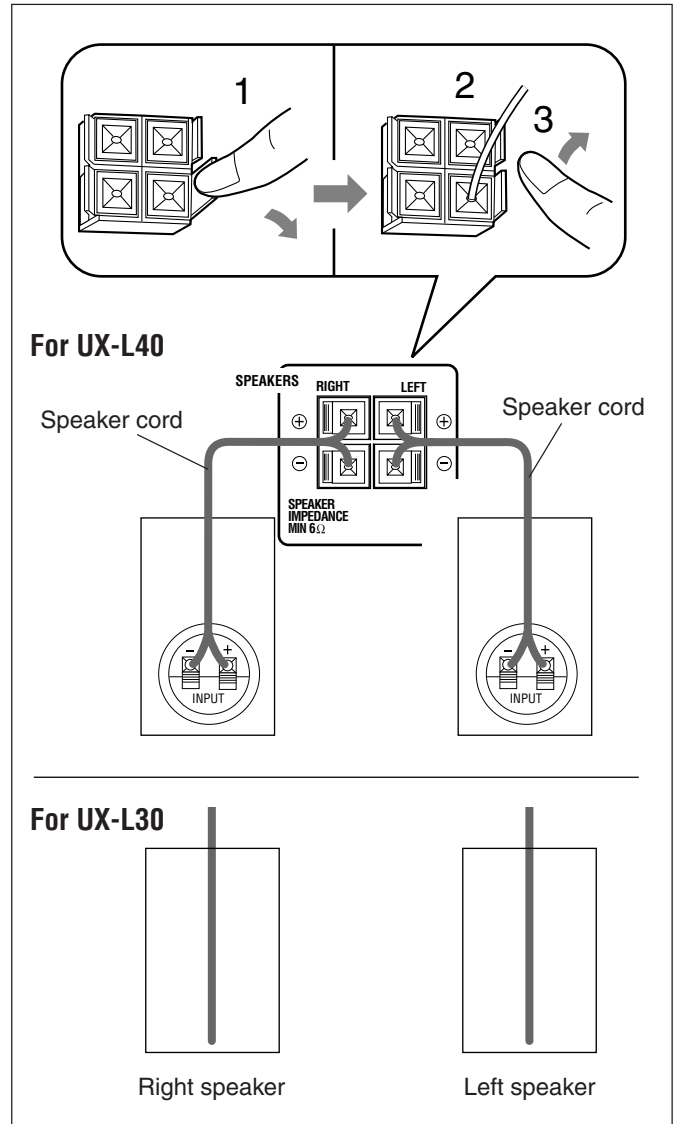

1 Press and hold the clamp of the speaker terminal on the rear of the unit.

2 Insert the end of the speaker cord to the terminal.

Match the polarity between the unit and the speaker terminals: (+) to (+) and (-) to (-).

- If cords are covered with insulation, twist the core of the cord at the end of each cord, then remove the insulation.

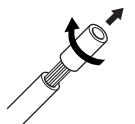

3 Release the finger from the clamp.

IMPORTANT: Use only speakers with the same speaker impedance as indicated by the speaker terminals on the rear of the unit.



To remove the speaker grilles

The speaker grilles are removable.

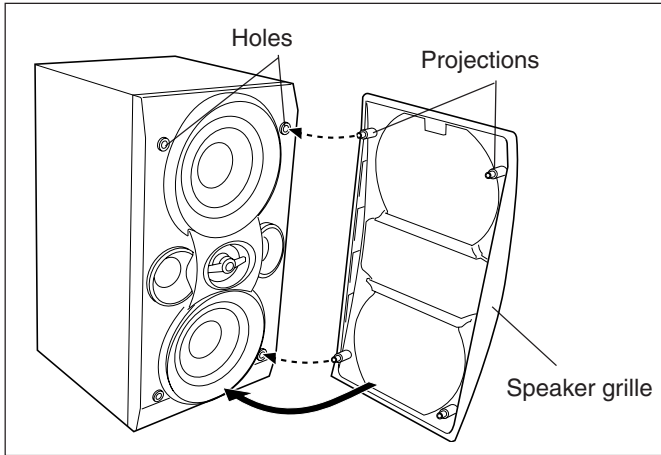

To remove the speaker grille, insert your fingers at the top of the speaker grille, pull towards you. Then pull the bottom towards you.

To attach the speaker grille, put the projections of the speaker grille into the holes of the speaker.

Connecting Other Equipment

You can connect both of the analog and digital equipment.

 • DO NOT connect any equipment while the power is on.
• DO NOT plug in any equipment until all connections are complete.

To connect audio equipment

Be sure that the plugs of the audio cords are colored: White plugs and jacks are for left audio signals, and red ones for right audio signals.

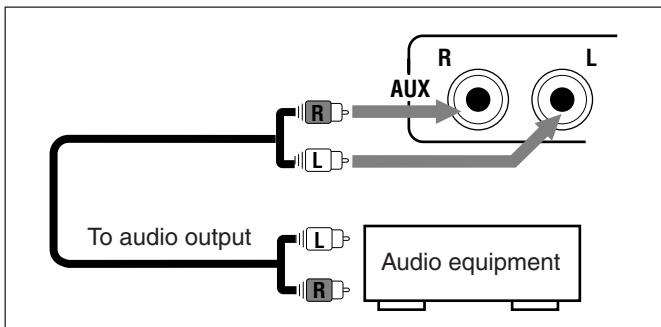

For playing the other equipment through this unit, connect between the audio output jacks on the other equipment and AUX jacks by using audio cords (not supplied).

To connect audio equipment with an optical digital input terminal

You can record CD sound onto the connected digital equipment.

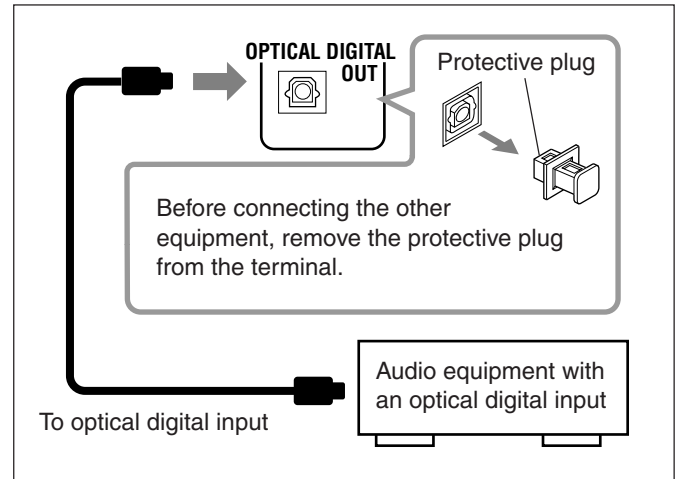

Connect an optical digital cord (not supplied) between the optical digital input terminal on the other equipment and the OPTICAL DIGITAL OUT terminal.

Adjusting the Voltage Selector

Before plugging in the unit, set the correct voltage for your area with the voltage selector on the rear of the unit.

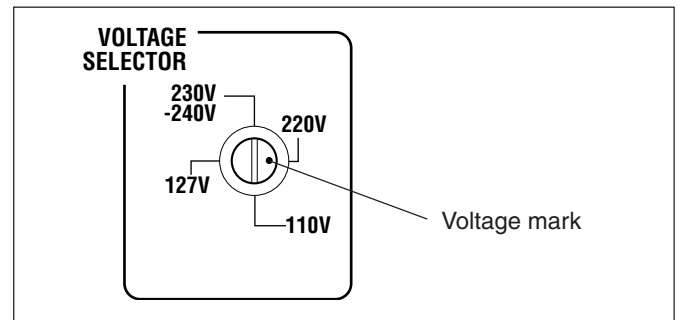

Use a screwdriver to rotate the voltage selector so the voltage number the voltage mark is pointing at is the same as the voltage where you are plugging in the unit. (See the back cover page.)

 DO NOT plug in before setting the voltage selector on the rear of the unit and all connection procedures are complete.

Now, you can plug the AC power cord.

- If the wall outlet does not match the AC plug, use the supplied AC plug adaptor.

IMPORTANT: Be sure to check all connections to be done before plugging the AC power cord into a wall outlet.

Common Operations

Setting the Clock

Before operating the unit any further, first set the clock built in this unit. When you plug the AC power cord into the wall outlet, “0:00” starts flashing on the display.

You can set the clock whether the unit is on or off.

- There is a time limit in doing the following steps. If the setting is canceled before you finish, start from step 1 again.

1 Press CLOCK/TIMER.

The hour digits start flashing on the display.

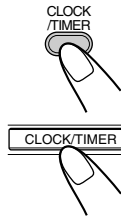

2 Press UP or DOWN to adjust the hour, then press CLOCK/TIMER.

The minute digits start flashing on the display.

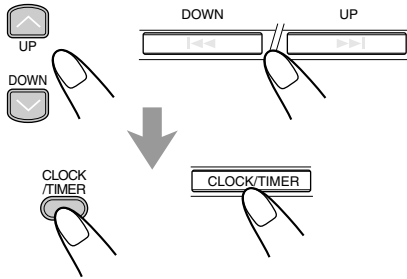

3 Press UP or DOWN to adjust the minute, then press CLOCK/TIMER.

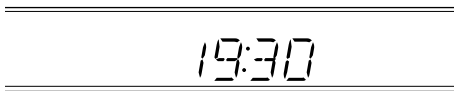

To adjust the clock again

- 1 **Make sure ☺ (timer) indicator is not lit on the display.**
 - If it is lit, press and hold CLOCK/TIMER until it goes off.
- 2 **Press CLOCK/TIMER repeatedly until the unit enters the clock setting mode (the hour digit start flashing on the display).**

First time you press CLOCK/TIMER, the unit enters the timer setting mode.

 - See pages 20 and 21.
- 3 **Repeat steps 2 and 3 of the procedure of “Setting the Clock.”**
- 4 **Press and hold CLOCK/TIMER again so that ☺ (timer) indicator goes off from the display.**

Setting the AM Tuner Interval Spacing

Some countries space AM stations 9 kHz apart, and some countries use 10 kHz spacing.

When shipped, the built-in AM tuner is set to 9 kHz spacing. You can change it to 9 kHz or 10 kHz spacing only while the unit is on standby.

On the unit ONLY:

To select 10 kHz intervals, press STANDBY/ON while holding .

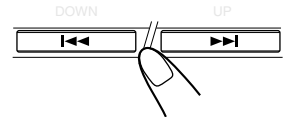

To select 9 kHz intervals, press STANDBY/ON while holding .

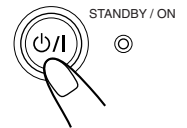

When you change the setting

The preset stations are erased. You will need to preset the stations again. (See page 12.)

To check the clock time during play

On the remote control ONLY:

Press DISPLAY.

- Each time you press the button, the source indication and the clock time alternate on the display.



- **When you unplug the AC power cord or if a power failure occurs**
The clock is reset to “0:00” right away. If this happens, set the clock again.
- **The clock may gain or lose 1 to 2 minutes per month**
If this happens, set the clock again.

Turning On the Power

When you press the play button—CD ►/II, TAPE ◀▶, FM/AM and AUX/MD, the unit automatically turns on and starts playback if the source is ready.

To turn on the unit, press STANDBY/ON .

The STANDBY/ON lamp lights green and “HELLO” appears on the display.

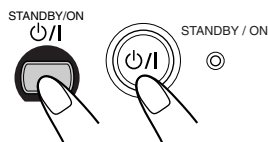

To turn off the unit (on standby), press STANDBY/ON .

again.

The STANDBY/ON lamp lights red and “GOOD BYE” appears on the display.

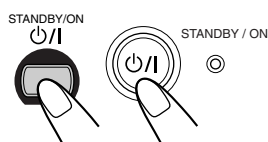

- “0:00” flashes on the display until you set the built-in clock. After setting the clock, the clock time will appear on the display while the unit is on standby.
- A little power is always consumed even while the unit is on standby.

To switch off the power supply completely, unplug the AC power cord from the AC outlet.



When you unplug the AC power cord or if a power failure occurs

The clock is reset to “0:00” right away, while the tuner preset stations (see page 12) will be erased in a few days.

Selecting the Sources and Starting Play

To play back CDs, press CD ►/II. (See pages 14 – 16.)

To play back tapes, press TAPE ◀▶. (See page 17.)

To listen to FM/AM broadcasts, press FM/AM. (See pages 12 – 13.)

To select the external equipment as the source, press AUX/MD.



When you press the play button for a particular source (CD ►/II, TAPE ◀▶, FM/AM and AUX/MD), the unit turns on (and the unit starts playing the source if it is ready).

Adjusting the Volume

You can adjust the volume level only while the unit is turned on. The volume level can be adjusted between “VOL MIN” and “VOLUME 1” – “VOLUME 40 (VOL MAX).”

When using the remote control, press VOLUME + to increase the volume or press VOLUME – to decrease it.



When using the unit, turn VOLUME + / – clockwise (+) to increase the volume or counterclockwise (–) to decrease it.

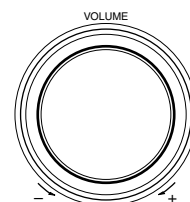
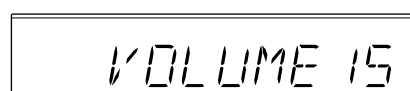

For private listening

Connect the headphones to the PHONES jack. No sound comes out of the speakers. Be sure to turn down the volume before connecting or putting on headphones.



DO NOT turn off (on standby) the unit with the volume set to an extremely high level; otherwise, a sudden blast of sound can damage your hearing, speakers and/or headphones when you turn on the unit or start playing any source next time. **REMEMBER** you cannot adjust the volume level while the unit is on standby.

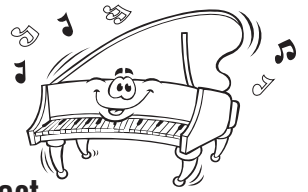

Adjusting the Tone (Bass/Treble)

You can adjust the bass level (low frequency range) and the treble level (high frequency range) within the range of -5 to $+5$. Normally set these to 0 (initial setting at factory).

- This function only affects the playback sound, but does not affect your recording.
- There is a time limit in doing the following steps. If the setting is canceled before you finish, start from step 1 again.

1 Press BASS to adjust the bass level or press TREBLE to adjust the treble level.

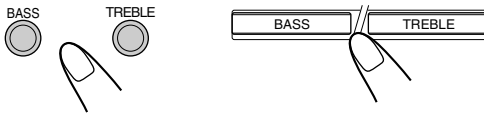

2 Press UP to increase the level or press DOWN to decrease it.

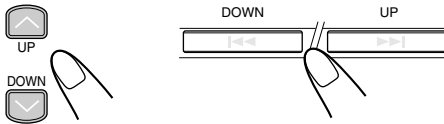

Reinforcing the Bass Sound

You can reinforce the bass sound to maintain rich, full bass at low volume.

- This function only affects the playback sound, but does not affect your recording.

To get the effect, press AHB (Active Hyper Bass) PRO until “AHB 1” or “AHB 2” appears on the display. The BASS indicator also lights up on the display.

- Each time you press the button, the bass sound change as follows:

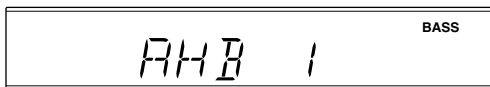
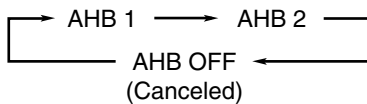

“AHB 2” has much more bass reinforcement effect than “AHB 1.”

To cancel the effect, press AHB PRO until “AHB OFF” appears on the display and the BASS indicator goes off.

Reinforcing the Surround Effect (ONLY FOR UX-L40)

You can reinforce the surround effect.

- This function does not affect
 - your recording.
 - playback sound of the monaural sources.

To get the effect, press SURROUND so that the SURROUND indicator lights up on the display.

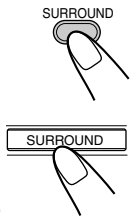

To cancel the effect, press SURROUND again so that the SURROUND indicator goes off.

Selecting the Illumination Brightness

You can change the illumination brightness only while the unit is turned on.

On the remote control ONLY:

To change the brightness, press DIMMER.

- Each time you press the button, the illumination dims and brightens alternately.



Tuning in to a Station

1 Press FM/AM to select the band.

The unit automatically turns on and tunes in to the previously received station (either FM or AM).

- Each time you press the button, the band alternates between FM and AM.

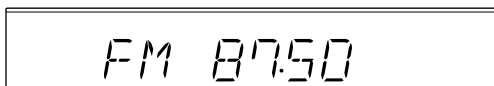

2 Press and hold >>> or <<< for more than 1 second.

The unit starts searching for stations and stops when a station of sufficient signal strength is tuned in.

If a program is broadcast in stereo, the ST (stereo) indicator lights up.

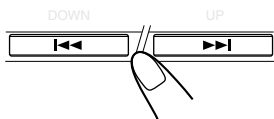

To stop searching, press >>> or <<<.



When you press >>> or <<< briefly and repeatedly

The frequency changes step by step.

To change the FM reception mode

On the remote control ONLY:

When an FM stereo broadcast is hard to receive or noisy, press FM MODE so that the MONO indicator lights up on the display. Reception improves.

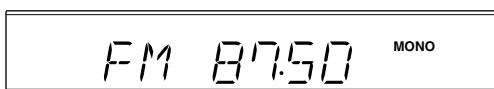

To restore the stereo effect, press FM MODE again so that the MONO indicator goes off. In this stereo mode, you can hear stereo sounds when a program is broadcasted.

Presetting Stations

You can preset 30 FM and 15 AM stations—using either automatic presetting or manual presetting.

In some cases, test frequencies have been already memorized for the tuner since the factory examined the tuner preset function before shipment. This is not a malfunction.

You can preset the stations you want into memory by following the presetting method.

To preset stations automatically—Automatic Presetting

You need to preset stations separately for the FM and AM bands.

On the remote control ONLY:

1 Press FM/AM to select the band you want to preset.

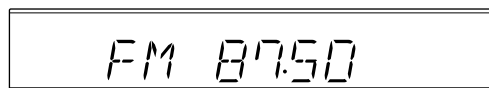

2 Press and hold AUTO PRESET for more than 2 seconds.

Local stations with strong signals are searched and stored in memory automatically.

When automatic presetting is over, the station stored in preset number 1 is received.



3 Repeat steps 1 and 2 to store stations for the other band.



- **When you cannot automatically store stations you want**
Stations with weak signals cannot be detected with this automatic presetting. To store such a station, use the manual presetting.
- **When you unplug the AC power cord or if a power failure occurs**

Preset stations with the automatic presetting are erased at once. If this happens, preset the stations again.



To preset stations manually—Manual Presetting

You need to preset stations separately for the FM and AM bands.

- There is a time limit in doing the following steps. If the setting is canceled before you finish, start from step 2 again.

On the remote control ONLY:

1 Tune in to the station you want to preset.

- See “Tuning in to a Station” on page 12.

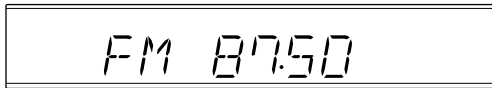

2 Press SET.



3 Press UP or DOWN to select a preset number.

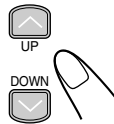
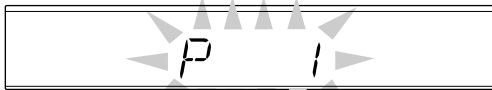

4 Press SET again.

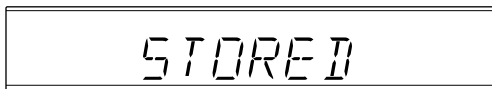

The tuned station in step 1 is stored in the preset number selected in step 3.

- Storing a new station on a used number erases the previously stored one.



When you unplug the AC power cord or if a power failure occurs

The tuner preset stations will be erased in a few days. If this happens, preset the stations again.

Tuning in to a Preset Station

On the remote control ONLY:

1 Press FM/AM to select the band.

The unit automatically turns on and tunes in to the previously received station (either FM or AM).

- Each time you press the button, the band alternates between FM and AM.

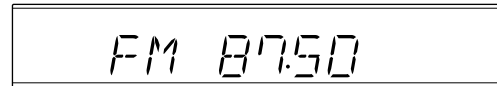

2 Press UP or DOWN to select a preset number.

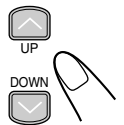

To tune a preset number directly using the number buttons

On the remote control ONLY:

Pressing the number button(s) allows you to select a preset number you want.

- Ex.:
- For preset number 5, press 5.
 - For preset number 15, press +10, then 5.
 - For preset number 20, press +10, then 10.
 - For preset number 30, press +10, +10, then 10.

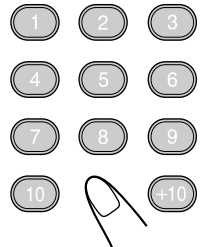

Playing Back CDs (CD/CD-R/CD-RW)

Continued 

This unit has been designed to playback the following CDs:

- CD
- CD-R
- CD-RW

Continued use of irregular shape CDs (heart-shape, octagonal, etc.) can damage the unit.

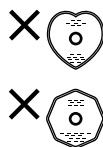

General Notes

In general, you will have the best performance by keeping your CDs and the mechanism clean.

- Store CDs in their cases, and keep them in cabinets or on shelves.
- Keep the unit's disc tray closed when not in use.

When playing a CD-R or CD-RW

User-edited CD-Rs (CD-Recordable) and CD-RWs (CD-ReWritable) can be played back only if they are already "finalized."

- You can play back your original CD-Rs or CD-RWs recorded in music CD format. However, they may not be played back depending on their characteristics or recording conditions.
- Before playing back CD-Rs or CD-RWs, read their instructions or cautions carefully.
- Some CD-Rs or CD-RWs may not be played back on this unit because of their disc characteristics, damage or stain on them, or if the player's lens is dirty.
- CD-RWs may require a longer readout time. This is caused by the fact that the reflectance of CD-RWs is lower than for regular CDs.

Playing Back the Entire CD—Normal Play

1 Press CD on the remote control (or on the unit).

The unit automatically turns on and the disc tray comes out.

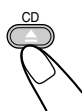

2 Place a disc correctly on the circle of the disc tray, with its label side up.

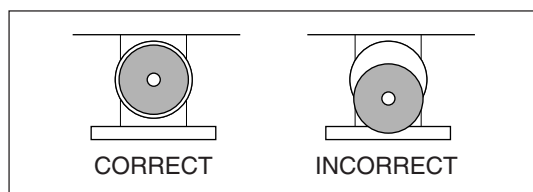

- When using a CD single (8 cm), place it on the inner circle of the disc tray.

3 Press CD .

The disc tray automatically closes and the first track of the CD starts playing.

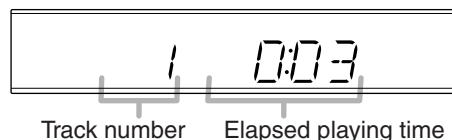

- The CD automatically stops when the last track of the CD has finished playing.

To stop playing, press .

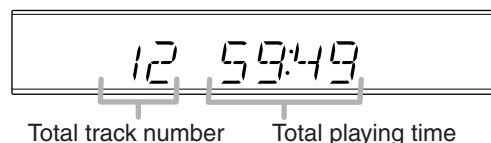

To remove the disc, press  CD on the remote control (or  on the unit).



- **If the CD cannot be read correctly (because it is scratched, for example) or an unreadable CD-R or CD-RW is inserted**
Playback will not start.
- **If no CD is inserted**
"NO DISC" appears on the display.
- **If the loaded CD has more than 21 tracks and you select 21st track or above**
"--:--" appears on the display instead of the playing time.



DO NOT try to open or close the CD tray by hand as it will be damaged.

Basic CD Operations

While playing a CD, you can do the following operations.

To stop playing for a moment

Press CD .



While pausing, the elapsed playing time flashes on the display.



To resume playing, press CD  again.

To go to another track

Press  or  repeatedly.

-  :
Skips to the beginning of the next or succeeding tracks.
-  :
Goes back to the beginning of the current or previous tracks.

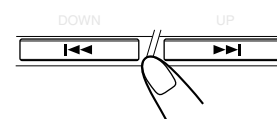

To go to another track directly using the number buttons

On the remote control ONLY:

Pressing the number button(s) allows you to start playing the track number you want.

- Ex.: For track number 5, press 5.
 For track number 15, press +10, then 5.
 For track number 20, press +10, then 10.
 For track number 32, press +10, +10, +10, then 2.

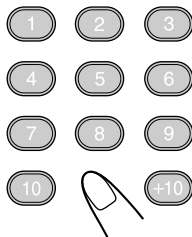

To locate a particular point in a track

During play, press and hold **▶▶** or **◀◀**.

- **▶▶**: Fast-forwards the tracks.
- **◀◀**: Fast-reverses the tracks.

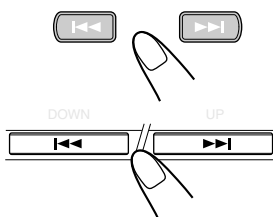

Programming the Playing Order of the Tracks —Program Play

You can arrange the order in which tracks play before you start playing. **You can program up to 20 tracks.**

On the remote control ONLY:

1 Load a CD.

- If the current playing source is not the CD player, press **CD ▶/||**, then **■** before going to the next step.

2 Press PRGM (program).

The PRGM (program) indicator lights up on the display.



- If a program has been stored in memory, the program is called up.

3 Press UP or DOWN to select the track number, then press SET.

- You can select the track number directly using the number buttons. (See “To go to another track directly using the number buttons.”)

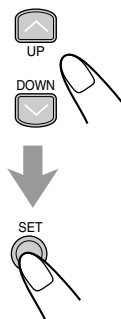
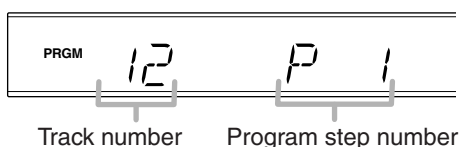

4 Repeat step 3 to program other tracks you want.

5 Press CD ▶/||.

The tracks are played in the order you have programmed.



To stop playing, press **■**.

To exit from Program Play mode, press PRGM before or after playing. The PRGM (program) indicator goes off.

To erase the program, press **■** twice.

- Disc ejection also erases the program.



If you try to program the 21st track “FULL” will appear on the display.

To check the program contents

You can check the program contents by pressing **▶▶** or **◀◀** before or after playback.

- **▶▶**:

To check the contents in the programmed order.

- **◀◀**:

To check the contents in the reverse order.

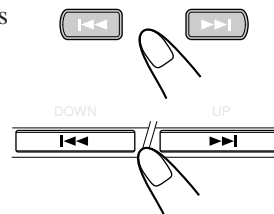

To modify the program

On the remote control ONLY:

Before or after playing, you can erase the last programmed track by pressing CANCEL.

- Each time you press the button, the last programmed track is erased from the program.



To add tracks in the program before playing, simply select the track numbers you want to add by following step 3 of the programming procedure.



Playing at Random—Random Play

The tracks will play in no particular order when you use this mode.

On the remote control ONLY:

1 Load a CD.

- If the current playing source is not the CD player, press CD ►/II, then ■ before going to the next step.

2 Press RANDOM.

The RANDOM indicator lights up on the display and the tracks start playing at random.



3 Press CD ►/II.

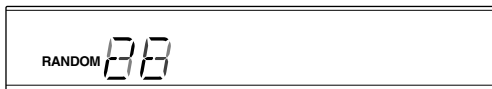

Random Play ends when all the tracks are played once.

To skip the current track, press ►►.

- You cannot go back to the previous track by pressing ◀◀.

To stop playing, press ■.

To exit from Random Play mode, press RANDOM again before or after playing. Random Play mode is canceled and Normal Play resumes.

- The RANDOM indicator goes off.

Repeating Tracks—Repeat Play

You can have all the tracks, the program or individual track currently playing to repeat as many times as you like.

On the remote control ONLY:

To repeat playing, press REPEAT before or during playing.

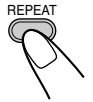

- Each time you press the button, Repeat Play mode changes as follows, and the following indicator lights up on the display:

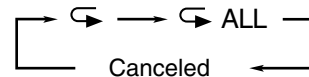

- ◀ : Repeats one track.
- ▶ ALL : In Normal Play mode, repeat all the tracks. In Program Play mode, repeat all the tracks in the program. In Random Play mode, repeats all the tracks in random order.

To stop playing, press ■.

To cancel Repeat Play mode, press REPEAT repeatedly until the repeat indicator goes off.

- Repeat Play mode remains in effect even when you change the play mode.
- In Random Play ▶ cannot be selected. If ▶ has been selected when you press RANDOM, it is canceled.

Prohibiting Disc Ejection—Tray Lock

You can lock the disc tray and prohibit to eject the CD.

- If the current playing source is not the CD player, press CD ►/II, then ■ before performing the procedure below.

On the unit ONLY:

To prohibit disc ejection, press STANDBY/ON ⏻/I while holding ■.

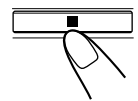

- If the disc tray is opened, close it first.

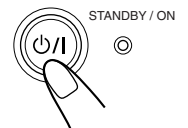

To cancel the prohibition and unlock the CD, press STANDBY/ON ⏻/I while holding ■.

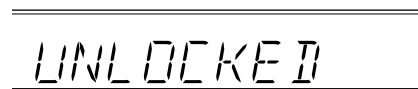

If you try to eject the CD while Tray Lock is in use “LOCKED” appears to inform you that the disc tray is locked.

Playing Back Tapes



You can play back type I, type II, and type IV tapes without changing any settings.

Playing Back a Tape

1 Press \blacktriangle PUSH OPEN on the unit.

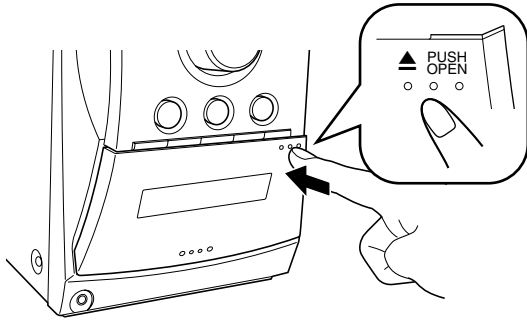

2 Put a cassette in with the exposed part of the tape down.

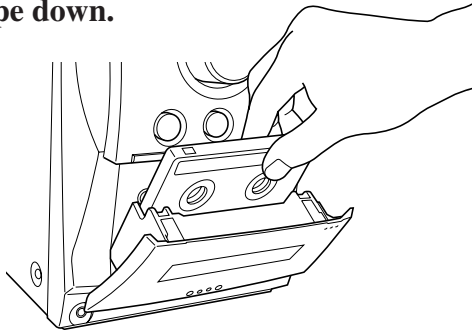

3 Press \blacktriangle PUSH OPEN again.

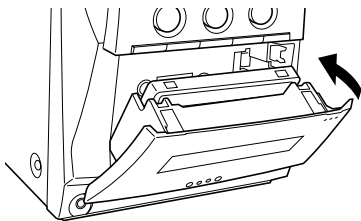

4 Press TAPE $\blacktriangle\blacktriangle$.

The unit automatically turns on and the tape starts playing. The tape direction indicator (\blacktriangleright or \blacktriangleleft) flashes slowly on the display.

- Each time you press the button, the tape direction changes.

- \blacktriangleright : plays the front side.
- \blacktriangleleft : plays the reverse side.



When the tape plays to the end, the deck automatically stops if the reverse mode is set to $\blacktriangleright\blacktriangleright$ or $\blacktriangleleft\blacktriangleleft$. (See “To play both sides—Reverse Mode.”)

To stop playing, press \blacksquare .

To fast-wind to the left or to the right, press $\blacktriangleright\blacktriangleright$ or $\blacktriangleleft\blacktriangleleft$ while the tape is not running.

The tape direction indicator (\blacktriangleright or \blacktriangleleft) starts flashing quickly on the display.

To remove the cassette, press \blacktriangle PUSH OPEN on the unit.

To play both sides—Reverse Mode

You can set the deck to play just one side of a tape, both sides once, or both sides continuously.

Press REV.MODE.

- Each time you press the button, reverse mode changes as follows:

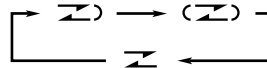

$\blacktriangleright\blacktriangleright$: The deck automatically stops after playing both sides of the tape. Stops when playback in the \blacktriangleleft direction is finished.

$\blacktriangleright\blacktriangleleft$: The deck continues to play both sides of the tape until \blacksquare is pressed.

$\blacktriangleleft\blacktriangleleft$: The deck automatically stops after playing one side of the tape.

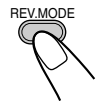

REV.MODE



On the unit
(only for UX-L30)



The use of the C-120 or thinner tape is not recommended, since characteristic deterioration may occur and this tape easily jams in the pinch-rollers and the capstans.



If no cassette is inserted

“NO TAPE” appears on the display.

IMPORTANT:

- It may be unlawful to record or play back copyrighted material without the consent of the copyright owner.
- The recording level is automatically set correctly, so it is not affected by the other sound settings. Thus, during recording you can adjust the sound you are actually listening to without affecting the recording level.
- If recordings you have made have excessive noise or static, the unit may be too close to a TV. Increase the distance between the TV and the unit.
- You can use type I tape for recording.

To protect your recording

Cassettes have two small tabs on the back to protect from unexpected erasure or re-recording.

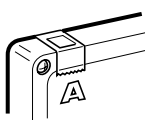

To protect your recording, remove these tabs.

To re-record on a protected tape, cover the holes with adhesive tape.

To keep the best recording and playback sound quality

If the heads, capstans, and pinch rollers of the cassette decks become dirty, the following will occur:

- Impaired sound quality
- Discontinuous sound
- Fading
- Incomplete erasure
- Difficulty in recording

To clean the heads, capstans, and pinch rollers

Use a cotton swab moistened with alcohol.

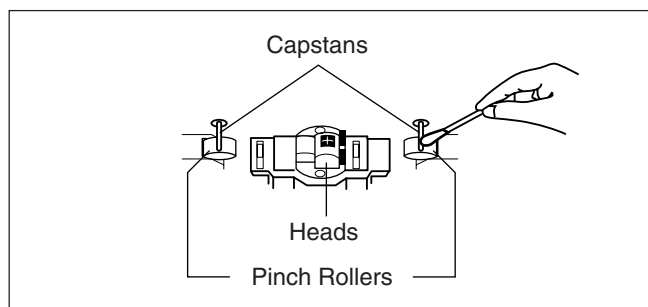

To demagnetize the heads

Turn off the unit, and use a head demagnetizer (available at electronics and audio shops).



At the start and end of cassette tapes

There is leader tape which cannot be recorded onto. Thus, when recording CDs or radio broadcasts, wind the leader tape first to ensure that the recording will be made without any music part lost.

Recording on a Tape

On the unit ONLY:

- 1 Put a recordable cassette in with the exposed part of the tape down.

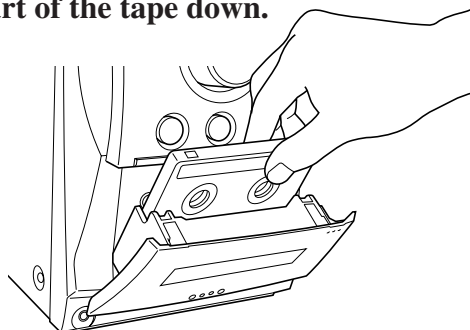

- 2 Close the cassette holder gently and check the recording direction for the tape.

- If the tape direction is not correct, press TAPE ◀▶ twice then ■ to change the tape direction.
- If you want to record on both sides of a tape, see “To record on both sides—Reverse Mode.”

- 3 Start playing the source—FM, AM or auxiliary equipment connected to AUX jacks.

- When the source is CD, see “CD Direct Recording” on page 19.

- 4 Press REC (recording).

The REC (recording) indicator lights up on the display and recording starts.

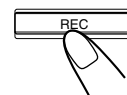

To stop recording, press ■.

The tape stops after 4 seconds.

To remove the cassette, press ▲ PUSH OPEN on the unit.

To record on both sides—Reverse Mode

Press REV.MODE (reverse mode) until the ⚡) indicator is lit.

- When using the Reverse Mode for recording, start recording in the forward (▶) direction first. Otherwise, recording will stop when recording is done only on one side (reverse) of the tape.



On the unit (only for UX-L30)



CD Direct Recording

Everything on the CD goes onto the tape in the order it is on the CD, or according to the order you have made for Program Play.

On the unit ONLY:

- 1 Put a recordable cassette in with the exposed part of the tape down.

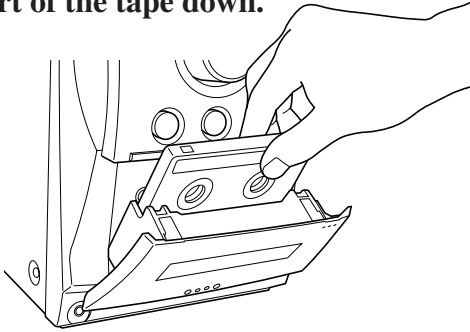

- 2 Load a CD.

- If the current playing source is not the CD player, press CD ►/||, then ■ before going to the next step.
 - If you do not want pauses of about 4 seconds recorded between selections, press CD ►/|| twice. Otherwise, non-recorded pause will be automatically recorded between selections.
- If you want to record on both sides of a tape, see “To record on both sides—Reverse Mode.”

- 3 Press REC (recording).

The REC (recording) indicator lights up on the display and recording starts. After recording, the CD player and cassette deck automatically stop.

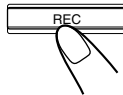

To stop while recording, press ■.

The tape stops after 4 seconds.

To remove the cassette, press ▲ PUSH OPEN on the unit.

To record on both sides—Reverse Mode

Press REV.MODE (reverse mode) until the ◀▶ indicator is lit.

- When using the Reverse Mode for CD Direct Recording, start recording in the forward (▶) direction first. When the tape reaches its end while recording a song in the forward direction (▶), the last song will be re-recorded at the beginning of the reverse side (◀).

If you start recording on the reverse side (◀), recording will stop when recording is done only on one side (reverse) of the tape.

REV.MODE



REV.MODE



On the unit
(only for UX-L30)

One Track Recording

This recording method is convenient when you record tracks while playing the CD. You can only record your favorite songs on the tape.

On the unit ONLY:

- 1 Put a recordable cassette in with the exposed part of the tape down.

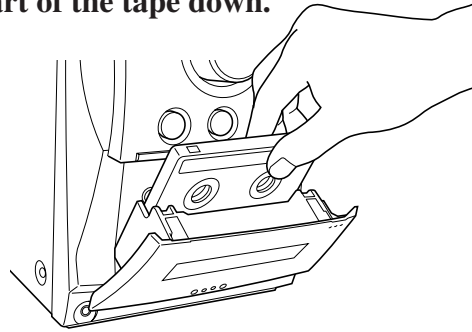

- 2 Play the track on the CD you wish to record.

- 3 Press REC (recording).

The CD player returns to the beginning of that track and the track is recorded on the tape.

After recording, the CD player and cassette deck automatically stop.

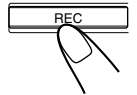

- 4 Repeat steps 2 and 3 to record other tracks you want.

To stop while recording, press ■.

The tape stops after 4 seconds.

To remove the cassette, press ▲ PUSH OPEN on the unit.



When making Sleep Timer settings while doing CD Direct recording

Set enough time to allow for the CD to finish playing; otherwise the power will go off before recording is completed.

There are three timers available—Daily Timer, Recording Timer and Sleep Timer.
Before using the timers, you need to set the clock built in the unit (see page 9).

Using Daily Timer and Recording Timer

You can set the timer whether the unit is on or off.

When the on-time comes, the unit automatically turns on (⊕ (timer) indicator flashes just before the on-time, and continues flashing while the timer is operating). Then, when the off-time comes, the unit automatically turns off (on standby).

The timer setting remains in memory until you change it.

- When the DAILY indicator is lit on the display, the timer acts as the Daily Timer. Once the Daily Timer has been set, it will be activated at the same time everyday until the timer is turned off.
- When the REC indicator is lit on the display, the timer acts as the Recording Timer. After the Recording Timer has been performed, the details of the setting remain stored but the timer is turned off.

Before you start...

When using “TUNER” as the source to play, make sure to select the desired station before turning off the power.

- There is a time limit in doing the following steps. If the setting is canceled before you finish, start from step 1 again.

1 Press CLOCK/TIMER.

⊕ (timer) indicator lights up, and the timer mode indicator (DAILY or REC) and the current on-time flash on the display.
The unit enters on-time setting mode.

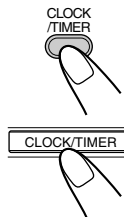

2 Set the on-time when you want the unit to turn on.

- 1) Press UP or DOWN to set the hour, then press CLOCK/TIMER.
- 2) Press UP or DOWN to set the minute, then press CLOCK/TIMER.

The unit enters off-time setting mode.

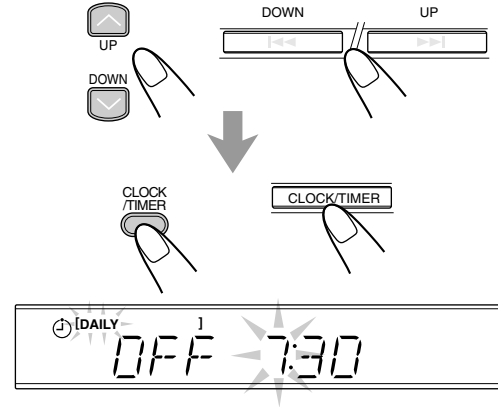

3 Set the off-time when you want the unit to turn off (on standby).

- 1) Press UP or DOWN to set the hour, then press CLOCK/TIMER.
- 2) Press UP or DOWN to set the minute, then press CLOCK/TIMER.

The unit enters source selecting mode.

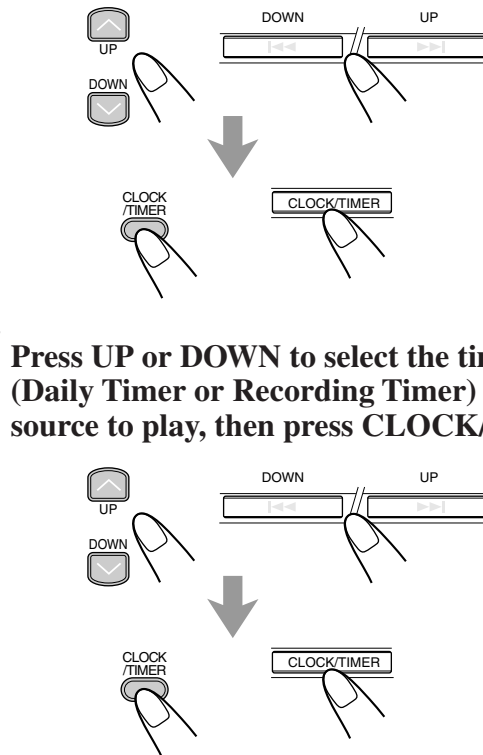

4 Press UP or DOWN to select the timer mode (Daily Timer or Recording Timer) and the source to play, then press CLOCK/TIMER.



- Each time you press these buttons, the timer mode and the source change as follows:

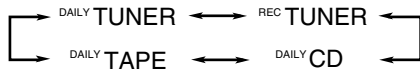

- DAILY TUNER** : tunes in to the last station you were listening to. (Daily Timer)
- REC TUNER** : records the last station you were listening to. (Recording Timer)
- Put a recordable cassette into the deck.
- DAILY CD** : plays a CD. (Daily Timer)
- Load a CD.
- DAILY TAPE** : plays a tape. (Daily Timer)
- Make sure that the tape direction is correct.

5 Press UP or DOWN to set the volume level, then press CLOCK/TIMER.

- You can select the volume level (“VOLUME --” and “VOLUME 0” to “VOLUME 40”).
If you select “VOLUME --,” the volume is set to the last level when the unit has been turned off.
- To turn off the volume while the Recording Timer (REC TUNER) is working,** set the volume level “VOLUME 0.”

The unit enters the clock setting mode.

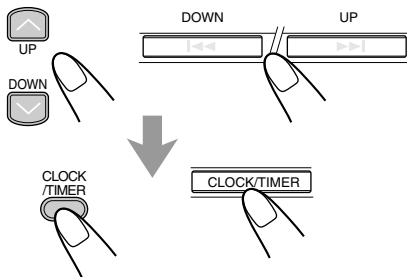



6 Adjust the clock.

- See “Setting the Clock” on page 9.

7 Press STANDBY/ON to turn off the unit (on standby) if you have set the timer with the unit turned on.

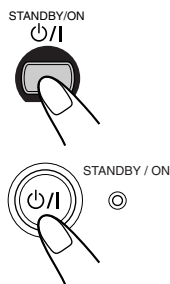
- When the timer turns on the unit,  (timer) indicator and the selected timer mode indicator (DAILY or REC) start flashing.



To cancel the setting, press and hold CLOCK/TIMER until  (timer) indicator goes off from the display.



- If the unit is turned on when the timer-on time comes**
Timer does not work.
- When you unplug the AC power cord or if a power failure occurs**
The timer will be canceled. You need to set the clock first, then the timer again.

Using Sleep Timer

With Sleep Timer, you can fall asleep to music.
You can set Sleep Timer when the unit is turned on.

How Sleep Timer actually works

The unit automatically turns off after the specified time length passes.

On the remote control ONLY:

1 Press SLEEP.

The time length until the shut-off time appears and the SLEEP indicator lights up on the display.



- Each time you press the button, the time length changes as follows:

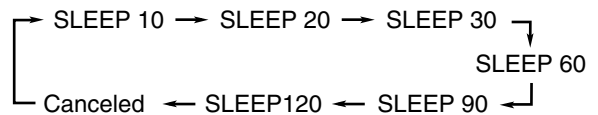

2 Wait for about 5 seconds after specifying the time length.

To check the remaining time until the shut-off time, press SLEEP once so that the remaining time until the shut-off time appears for about 5 seconds.

To change the shut-off time, press SLEEP repeatedly until the desired time length appears on the display.

To cancel the setting, press SLEEP repeatedly until the SLEEP indicator goes off.

- Sleep Timer is also canceled when you turn off the unit.



- If you set the Sleep Timer after Daily Timer starts playing the selected source**
Daily Timer is canceled.
- If you set the Sleep Timer after Recording Timer starts recording**
Recording Timer is canceled, but recording continues until Sleep Timer shuts off the power.

Troubleshooting



If you are having a problem with your unit, check this list for a possible solution before calling for service.

If you cannot solve the problem from the hints given here, or the unit has been physically damaged, call a qualified person, such as your dealer, for service.

Symptom	Cause	Action
No sound is heard.	<ul style="list-style-type: none"> • Connections are incorrect or loose. • Headphones are connected. 	<ul style="list-style-type: none"> • Check all connections and make corrections. (See pages 6 to 8.) • Disconnect the headphones.
Hard to listen to broadcasts because of noise.	<ul style="list-style-type: none"> • Antennas are disconnected. • The AM loop antenna is too close to the unit. • The FM antenna is not properly extended and positioned. 	<ul style="list-style-type: none"> • Reconnect the antennas correctly and securely. • Change the position and direction of the AM loop antenna. • Extend the FM antenna at the best position.
The disc tray does not open or close.	The AC power cord is not plugged in.	Plug the AC power cord.
The disc does not play.	The disc is placed upside down.	Place the disc with the label side up.
The disc sound is discontinuous.	The disc is scratched or dirty.	Clean or replace the disc. (See page 23.)
The cassette holder cannot be opened.	Power supply from the AC power cord has been cut off while the tape was running.	Turn on the unit.
Impossible to record.	Small tabs on the back of the cassette are removed.	Cover the holes with adhesive tape.
Operations are disabled.	The built-in microprocessor may malfunction due to external electrical interference.	Unplug the AC power cord and then plug it back in.
Unable to operate the unit from the remote control.	<ul style="list-style-type: none"> • The path between the remote control and the remote sensor on the unit is blocked. • The batteries are exhausted. 	<ul style="list-style-type: none"> • Remove the obstruction. • Replace the batteries.

Maintenance



To get the best performance of the unit, keep your discs, tapes, and mechanism clean.

Handling discs



- Remove the disc from its case by holding it at the edge while pressing the center hole lightly.
- Do not touch the shiny surface of the disc, or bend the disc.
- Put the disc back in its case after use to prevent warping.

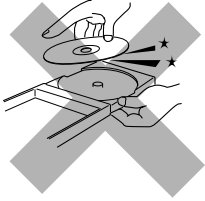

- Be careful not to scratch the surface of the disc when placing it back in its case.
- Avoid exposure to direct sunlight, temperature extremes, and moisture.



To clean the disc

Wipe the disc with a soft cloth in a straight line from center to edge.

DO NOT use any solvent—such as conventional record cleaner, spray, thinner, or benzine—to clean the disc.

Cleaning the unit

• Stains on the unit

- Should be wiped off with a soft cloth. If the unit is heavily stained, wipe it with a cloth soaked in water-diluted neutral detergent and wrung well, then wipe clean with a dry cloth.
- **Since the unit may deteriorate in quality, become damaged or get its paint peeled off, be careful about the followings.**
 - DO NOT wipe it with a hard cloth.
 - DO NOT wipe it strong.
 - DO NOT wipe it with thinner or benzine.
 - DO NOT apply any volatile substance such as insecticides to it.
 - DO NOT allow any rubber or plastic to remain in contact with it for a long time.

Handling cassette tapes

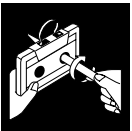

- If the tape is loose in its cassette, take up the slack by inserting a pencil in one of the reels and rotating.
- If the tape is loose, it may get stretched, cut, or caught in the cassette.



- Be careful not to touch the tape surface.



- Avoid the following places to store the tape:
 - In dusty places
 - In direct sunlight or heat
 - In moist areas
 - On a TV or speaker
 - Near a magnet

Specifications

Design and specifications are subject to change without notice.

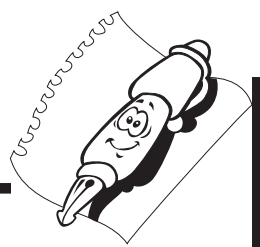

UX-L40 (CA-UXL40 and SP-UXL40)

Amplifier

Output Power:
120 W (60 W + 60 W) at 6 Ω (MAX.)
100 W (50 W + 50 W) at 6 Ω (10% THD)
Audio input sensitivity/Impedance (at 1 kHz)
AUX: 400 mV/48 kΩ
Digital output—OPTICAL DIGITAL OUT
Signal wave length: 660 nm
Output level: -21 dBm to -15 dBm
Speakers/Impedance: 6 Ω – 16 Ω

Tuner

FM tuning range: 87.50 MHz – 108.00 MHz
AM tuning range:
At 9 kHz intervals: 531 kHz – 1 710 kHz
At 10 kHz intervals: 530 kHz – 1 710 kHz

CD player

Dynamic range: 85 dB
Signal-to-noise ratio: 90 dB
Wow and flutter: Immeasurable

Cassette deck

Frequency response:
Normal (type I): 60 Hz – 14 000 Hz
Wow and flutter: 0.15% (WRMS)

General

Power requirement:
AC 110 V/ 127 V/ 220 V/ 230 V – 240 V \sim , adjustable
with the voltage selector, 50 Hz/60 Hz
Power consumption: 90 W (at operation)
7.2 W (on standby)
Dimensions (approx.):
170 mm x 286 mm x 319.5 mm (W/H/D)
Mass (approx.): 12.7 kg

Supplied Accessories

See page 6.

Speaker

Speaker units: Woofer: 10.0 cm cone x 2
Tweeter: 4.0 cm cone x 1
Impedance: Main speaker: 6 Ω
Dimensions (approx.):
175 mm x 320 mm x 229 mm (W/H/D)
Mass (approx.): 3.0 kg each

UX-L30 (CA-UXL30 and SP-UXL30)

Amplifier

Output Power:
120 W (60 W + 60 W) at 6 Ω (MAX.)
100 W (50 W + 50 W) at 6 Ω (10% THD)
Audio input sensitivity/Impedance (at 1 kHz)
AUX: 400 mV/48 kΩ
Digital output—OPTICAL DIGITAL OUT
Signal wave length: 660 nm
Output level: -21 dBm to -15 dBm
Speakers/Impedance: 6 Ω – 16 Ω

Tuner

FM tuning range: 87.50 MHz – 108.00 MHz
AM tuning range:
At 9 kHz intervals: 531 kHz – 1 710 kHz
At 10 kHz intervals: 530 kHz – 1 710 kHz

CD player

Dynamic range: 85 dB
Signal-to-noise ratio: 90 dB
Wow and flutter: Immeasurable

Cassette deck

Frequency response:
Normal (type I): 60 Hz – 14 000 Hz
Wow and flutter: 0.15% (WRMS)

General

Power requirement:
AC 110 V/ 127 V/ 220 V/ 230 V – 240 V \sim , adjustable
with the voltage selector, 50 Hz/60 Hz
Power consumption: 90 W (at operation)
7.2 W (on standby)
Dimensions (approx.):
170 mm x 286 mm x 319.5 mm (W/H/D)
Mass (approx.): 12.7 kg

Supplied Accessories

See page 6.

Speaker

Speaker units: Woofer: 12.0 cm cone x 1
Tweeter: 4.0 cm cone x 1
Impedance: Main speaker: 6 Ω
Dimensions (approx.):
160 mm x 285 mm x 186.5 mm (W/H/D)
Mass (approx.): 2.4 kg each

Mains (AC) Line Instruction (not applicable for Europe, U.S.A., Canada, Australia, and U.K.)

主 (AC) 电源线路说明 (不适用于欧洲、美国、加拿大、澳洲及英国型号)

VOLTAGE SELECTOR

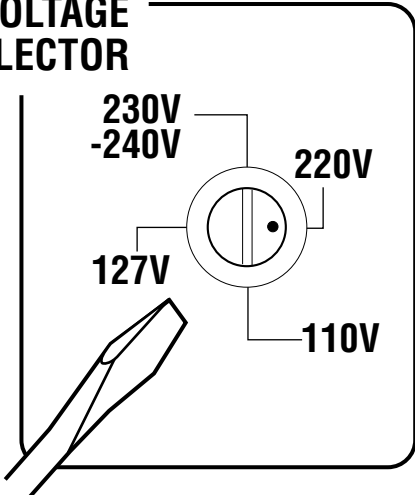

IMPORTANT for mains (AC) line
BEFORE PLUGGING IN, do check that your mains (AC) line voltage corresponds with the position of the voltage selector switch provided on the outside of this equipment and, if different, reset the voltage selector switch, to prevent from a damage or risk of fire/electric shock.

有关主 (AC) 电源线路的重要事项
接插电源以前，务请检查当地的主 (AC) 电源线路电压是否和位于本机外面的电压选择开关设定的位置一致。如果不一致，即重新设定电压选择开关使符合当地电压，以免损坏机器或引起火灾/触电的危险。

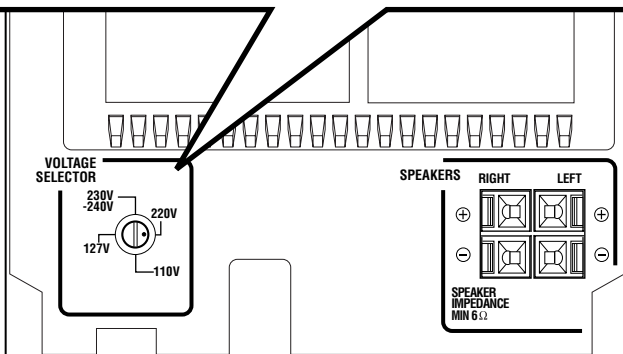

JVC

VICTOR COMPANY OF JAPAN, LIMITED

JVC



MICRO COMPONENT SYSTEM SISTEMAS DE MICROCOMPONENTES SISTEMA DE MICRO COMPONENTES

UX-L40— Consists of CA-UXL40 and SP-UXL40

UX-L30— Consists of CA-UXL30 and SP-UXL30

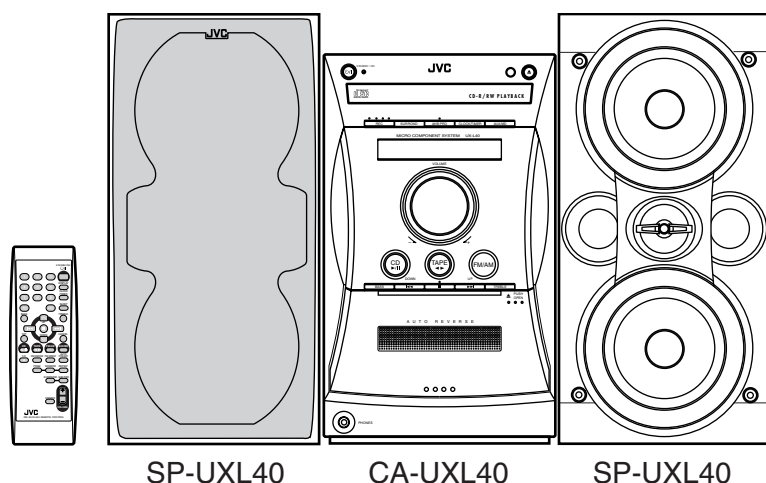

SP-UXL40

CA-UXL40

SP-UXL40

COMPACT
disc
DIGITAL AUDIO

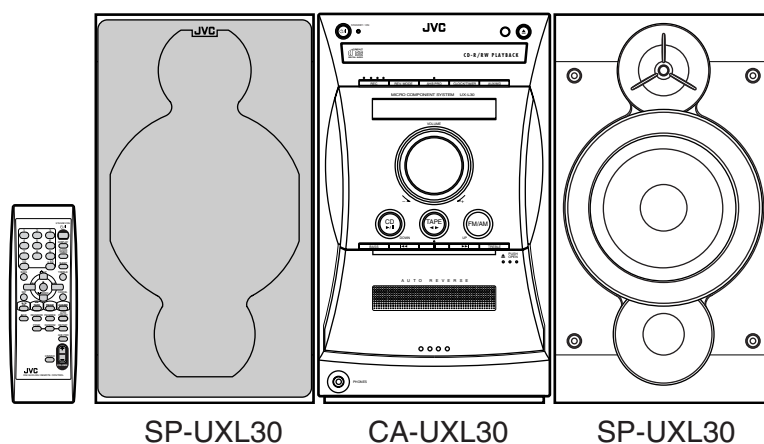

SP-UXL30

CA-UXL30

SP-UXL30

INSTRUCTIONS MANUAL DE INSTRUCCIONES INSTRUÇÕES

For Customer Use:

Enter below the Model No. and Serial No. which are located either on the rear, bottom or side of the cabinet. Retain this information for future reference.

Model No. _____

Serial No. _____

GVT0080-013A
[UW, UY]

Warnings, Cautions and Others

Avisos, precauciones y otras notas

Advertências, precauções e outras notas

CAUTION—STANDBY/ON button!

Disconnect the mains plug to shut the power off completely (the STANDBY/ON lamp goes off). The STANDBY/ON  button in any position does not disconnect the mains line.

- When the unit is on standby, the STANDBY/ON lamp lights red.
- When the unit is turned on, the STANDBY/ON lamp lights green.

The power can be remote controlled.

Precaución—Interruptor STANDBY/ON /!

Desconecte el enchufe de la red para desconectar la alimentación por completo (la lámpara STANDBY/ON se apaga). El interruptor STANDBY/ON /! desconectará completamente la alimentación principal, cualquiera que sea su posición.

- Cuando la unidad está en espera, la lámpara STANDBY/ON se enciende en rojo.
- Cuando conecta la unidad, la lámpara STANDBY/ON se enciende en verde.

La alimentación puede ser controlada a distancia.

Precaução—botão STANDBY/ON /!

Desligue a ficha do interruptor para cortar completamente a corrente eléctrica (a lâmpada de STANDBY/ON - dormir activado-apaga-se). O botão STANDBY/ON /!, em qualquer posição, não desliga completamente a corrente eléctrica.

- Quando o aparelho está em standby (dormir) a lâmpada STANDBY/ON (dormir activado) fica vermelha.
 - Quando o aparelho está ligado a lâmpada STANDBY/ON (dormir activado) fica verde.
- O aparelho pode ser ligado através da unidade de controlo remoto.

CAUTION

To reduce the risk of electrical shocks, fire, etc.:

1. Do not remove screws, covers or cabinet.
2. Do not expose this appliance to rain or moisture.

PRECAUCIÓN

Para reducir riesgos de choques eléctricos, incendio, etc.:

1. No extraiga los tornillos, los cubiertas ni la caja.
2. No esponga este aparato a la lluvia o a la humedad.

PRECAUÇÃO

Para reduzir riscos de choques eléctricos, incêndio, etc.:

1. Não remova parafusos e tampas ou desmonte a caixa.
2. Não exponha este aparelho à chuva nem à umidade.

CAUTION

- Do not block the ventilation openings or holes. (If the ventilation openings or holes are blocked by a newspaper or cloth, etc., the heat may not be able to get out.)
- Do not place any naked flame sources, such as lighted candles, on the apparatus.
- When discarding batteries, environmental problems must be considered and local rules or laws governing the disposal of these batteries must be followed strictly.
- Do not expose this apparatus to rain, moisture, dripping or splashing and that no objects filled with liquids, such as vases, shall be placed on the apparatus.

PRECAUCIÓN

- No obstruya las rendijas o los orificios de ventilación. (Si las rendijas o los orificios de ventilación quedan tapados con un periódico, un trozo de tela, etc., no se podrá disipar el calor.)
- No ponga sobre el aparato ninguna llama al descubierto, como velas encendidas.
- Cuando tenga que descartar las pilas, tenga en cuenta los problemas ambientales y observe estrictamente los reglamentos o las leyes locales sobre disposición de las pilas.
- No esponga este aparato a la lluvia, humedad, goteos o salpicaduras. Tampoco ponga recipientes conteniendo líquidos, como floreros, encima del aparato.

PRECAUÇÃO

- Não obstrua as aberturas e orifícios de ventilação. (Se os orifícios ou aberturas de ventilação estiverem obstruídos por qualquer papel ou tecido, não haverá circulação do ar quente.)
- Não coloque nenhum objeto com chamas, como velas acesas, sobre o aparelho.
- Ao descartar as baterias, leve em consideração os problemas que possam ser causados ao meio ambiente e os regulamentos e leis locais e governamentais sobre recolhimento dessas baterias devem ser rigorosamente seguidos.
- Não exponha este aparelho à chuva, umidade, pingos ou esguichos de água, nem coloque em cima do mesmo qualquer tipo de recipiente que contenha líquidos, como por exemplo vasos.

REPRODUCTION OF LABELS / REPRODUCCIÓN DE ETIQUETAS / REPRODUÇÃO DE ETIQUETAS

- ① CLASSIFICATION LABEL, PLACED ON EXTERIOR SURFACE
- ① ETIQUETA DE CLASIFICACIÓN, PROVISTA SOBRE LA SUPERFICIE EXTERIOR
- ① ETIQUETA DE CLASSIFICAÇÃO LOCALIZADA NA PARTE POSTERIOR DA CAIXA DO APARELHO

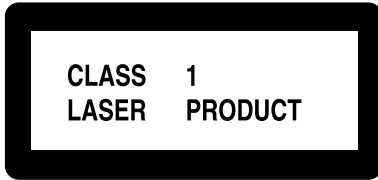

- ② WARNING LABEL, PLACED INSIDE THE UNIT
- ② ETIQUETA DE ADVERTENCIA, PEGADA EN EL INTERIOR DE LA UNIDAD
- ② ETIQUETA DE ADVERTÊNCIA LOCALIZADA NA PARTE INTERNA DA UNIDADE

1. CLASS 1 LASER PRODUCT
2. **CAUTION:** Invisible laser radiation when open and interlock failed or defeated. Avoid direct exposure to beam.
3. **CAUTION:** Do not open the top cover. There are no user serviceable parts inside the Unit; leave all servicing to qualified service personnel.

1. PRODUCTO LÁSER CLASE 1
2. **PRECAUCIÓN:** En el interior hay radiación láser invisible. Evite el contacto directo con el haz.
3. **PRECAUCIÓN:** No abra la tapa superior. En el interior de la unidad no existen piezas reparables por el usuario; deje todo servicio técnico en manos de personal calificado.

1. PRODUTO LASER CLASSE 1
2. **CUIDADO:** O laser emite uma radiação invisível que é perigosa, caso o aparelho esteja aberto e a trava inoperante ou danificada. Evite exposição direta ao feixe dos raios.
3. **CUIDADO:** Não abra a caixa do aparelho. Não existem peças reparáveis pelo usuário na parte interna da unidade. Solicite assistência técnica somente a pessoal técnico qualificado.

CAUTION: Invisible laser radiation when open and interlock failed or defeated. AVOID DIRECT EXPOSURE TO BEAM. (e)

ADVARSEL: Usynlig laserstråling ved åbning, når sikkerhedsafbrydere er ude af funktion. Undgå udsættelse for stråling. (d)

WARNING: Osynlig laserstråling när denna del är öppnad och spårren är urkopplad. Betrakta ej strålen. (s)

VARO: Avattaessa ja suojalukitus ohitettaessa olet alttiina näkymättömälle lasersäteilylle. Älä katso säteeseen. (f)

CAUTION: Proper Ventilation

To avoid risk of electric shock and fire, and to prevent damage, locate the apparatus as follows:

- 1 Front: No obstructions and open spacing.
- 2 Sides/ Top/ Back: No obstructions should be placed in the areas shown by the dimensions below.
- 3 Bottom: Place on the level surface. Maintain an adequate air path for ventilation by placing on a stand with a height of 10 cm or more.

Precaución: el aparato debe estar bien ventilado

Para evitar posibles riesgos de descargas eléctricas e incendios y prevenir cualquier posible daño, coloque el aparato del modo siguiente:

- 1 Parte delantera: No ponga nada delante, deje el espacio libre.
- 2 Laterales/ parte superior/ parte trasera: No se debería colocar nada en las áreas y las distancias que se detallan a continuación.
- 3 Parte inferior: Coloque el aparato sobre una superficie recta. Debe haber buena circulación de aire; para ello, coloque el aparato sobre una base a una altura mínima de 10 cm.

Precaução: Ventilação adequada

Para evitar riscos de choques elétricos e incêndios, e prevenir avarias, instale o aparelho como segue:

- 1 Parte frontal: Sem obstruções e espaços abertos.
- 2 Partes laterais/ Tampa/ Posterior: Nenhuma obstrução deverá ser colocada entre as áreas cujas dimensões são indicadas abaixo.
- 3 Parte inferior: Instale-o sobre uma superfície plana. Deverá ser mantido espaço suficiente para a ventilação se este for instalado numa posição que tenha uma altura de 10 cm ou mais.

Front view
Vista frontal
Vista frontal

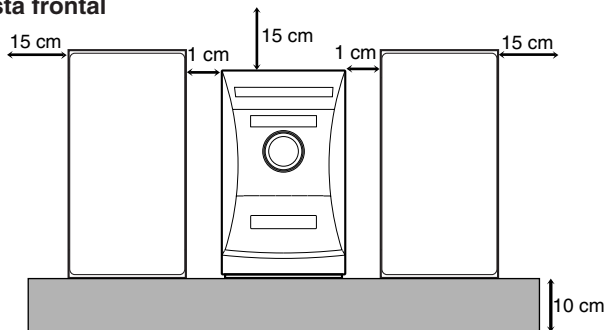

UX-L40/UX-L30

Side view
Vista lateral
Vista lateral

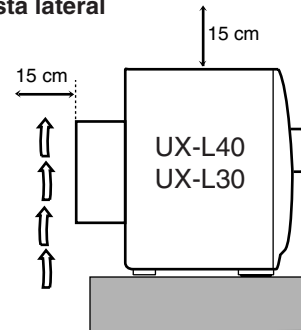

Introduction

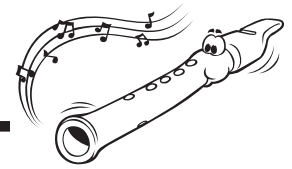

We would like to thank you for purchasing one of our JVC products. Before operating this unit, read this manual carefully and thoroughly to obtain the best possible performance from your unit, and retain this manual for future reference.

About This Manual

This manual is organized as follows:

- **The manual mainly explains operations using the buttons on the remote control.**
You can use the buttons both on the remote control and on the unit for the same operations if they have the same or similar names (or marks), unless mentioned otherwise.
- Basic and common information that is the same for many functions is grouped in one place, and is not repeated in each procedure. For instance, we do not repeat the information about turning on/off the unit, setting the volume, changing the sound effects, and others, which are explained in the section “Common Operations” on pages 9 and 11.
- The following marks are used in this manual:



Gives you warnings and cautions to prevent from damage or risk of fire/electric shock. Also gives you information which is not good for obtaining the best possible performance from the unit.



Gives you information and hints you had better know.

The illustrations used in this manual are of UX-L40 unless mentioned otherwise.

Precautions

Installation

- Install in a place which is level, dry and neither too hot nor too cold—between 5°C and 35°C.
- Install the unit in a location with adequate ventilation to prevent internal heat built-up in the unit.
- Leave sufficient distance between the unit and the TV.
- Keep the speakers away from the TV to avoid interference with TV.



DO NOT install the unit in a location near heat sources, or in a place subject to direct sunlight, excessive dust or vibration.

Power sources

- When unplugging from the wall outlet, always pull the plug, not the AC power cord.



DO NOT handle the AC power cord with wet hands.

Moisture condensation

Moisture may condense on the lens inside the unit in the following cases:

- After starting heating in the room
 - In a damp room
 - If the unit is brought directly from a cold to a warm place
- Should this occur, the unit may malfunction. In this case, leave the unit turned on for a few hours until the moisture evaporates, unplug the AC power cord, and then plug it in again.

Others

- Should any metallic object or liquid fall into the unit, unplug the unit and consult your dealer before operating any further.
- If you are not going to operate the unit for an extended period of time, unplug the AC power cord from the wall outlet.



DO NOT disassemble the unit since there are no user serviceable parts inside.

If anything goes wrong, unplug the AC power cord and consult your dealer.

Contents

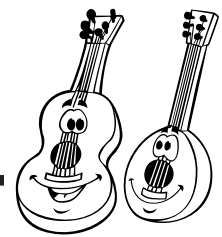

Location of the Buttons and Controls	3	Playing Back CDs (CD/CD-R/CD-RW)	14
Remote Control	3	Playing Back the Entire CD—Normal Play	14
Front Panel	4	Basic CD Operations	14
Getting Started	6	Programming the Playing Order of the Tracks	
Supplied Accessories	6	—Program Play	15
Putting the Batteries into the Remote Control	6	Playing at Random—Random Play	16
Connecting Antennas	6	Repeating Tracks—Repeat Play	16
Connecting Speakers	7	Prohibiting Disc Ejection—Tray Lock	16
Connecting Other Equipment	8	Playing Back Tapes	17
Adjusting the Voltage Selector	8	Playing Back a Tape	17
Common Operations	9	Recording	18
Setting the Clock	9	Recording on a Tape	18
Setting the AM Tuner Interval Spacing	9	CD Direct Recording	19
Turning On the Power	10	One Track Recording	19
Selecting the Sources and Starting Play	10	Using the Timers	20
Adjusting the Volume	10	Using Daily Timer and Recording Timer	20
Adjusting the Tone (Bass/Treble)	11	Using Sleep Timer	21
Reinforcing the Bass Sound	11	Troubleshooting	22
Reinforcing the Surround Effect		Maintenance	23
(ONLY FOR UX-L40)	11	Specifications	24
Selecting the Illumination Brightness	11		
Listening to FM and AM Broadcasts	12		
Tuning in to a Station	12		
Presetting Stations	12		
Tuning in to a Preset Station	13		

Location of the Buttons and Controls

Become familiar with the buttons and controls on your unit.

Remote Control

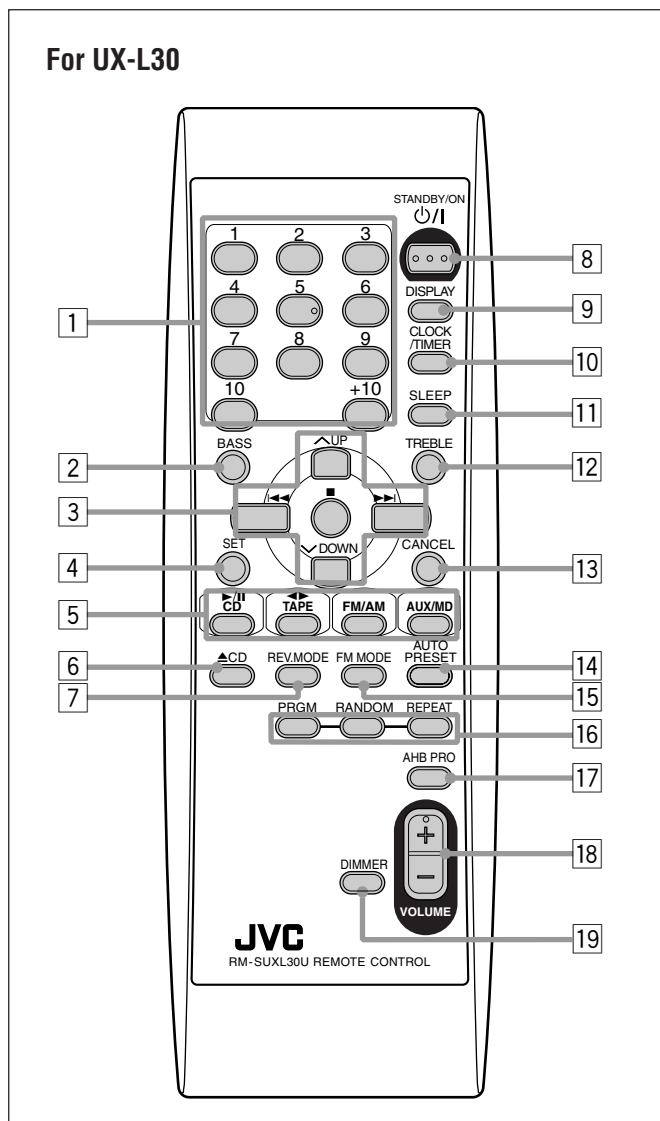
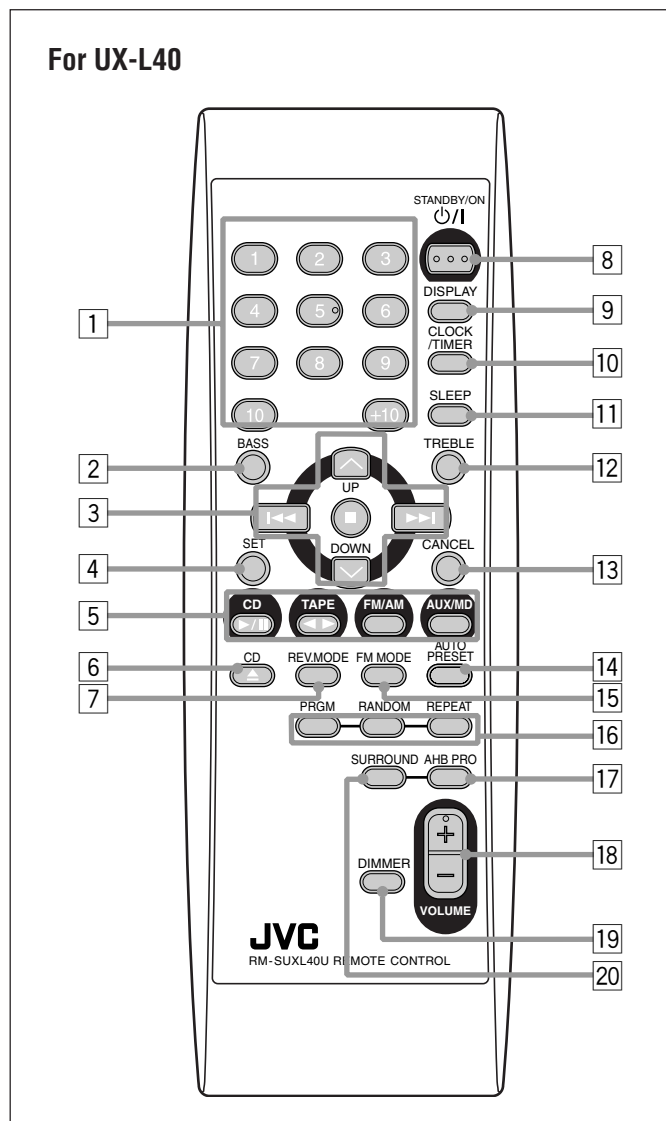

See pages in the parentheses for details.

Remote Control

- 1 Number buttons
- 2 BASS button (11)
- 3 Multi operation buttons
 - UP, ◀◀ (reverse skip), ■ (stop), ▶▶ (forward skip) and DOWN
- 4 SET button (13, 15)
- 5 Source buttons
 - CD ▶/||, TAPE ◀▶, FM/AM and AUX/MD
 Pressing one of these buttons also turns on the unit.
- 6 ▲ CD (disc tray open/close) button (14)
Pressing this button also turns on the unit.
- 7 REV.MODE (reverse mode) button (17 – 19)

- 8 STANDBY/ON ⏻/| button (10, 21)
- 9 DISPLAY button (9)
- 10 CLOCK/TIMER button (9, 20, 21)
- 11 SLEEP button (21)
- 12 TREBLE button (11)
- 13 CANCEL button (15)
- 14 AUTO PRESET button (12)
- 15 FM MODE button (12)
- 16 CD play mode buttons (15, 16)
 - PRGM (program), RANDOM and REPEAT
- 17 AHB (Active Hyper Bass) PRO button (11)
- 18 VOLUME + / - button (10)
- 19 DIMMER button (11)
- 20 SURROUND button (ONLY FOR UX-L40) (11)

Front Panel

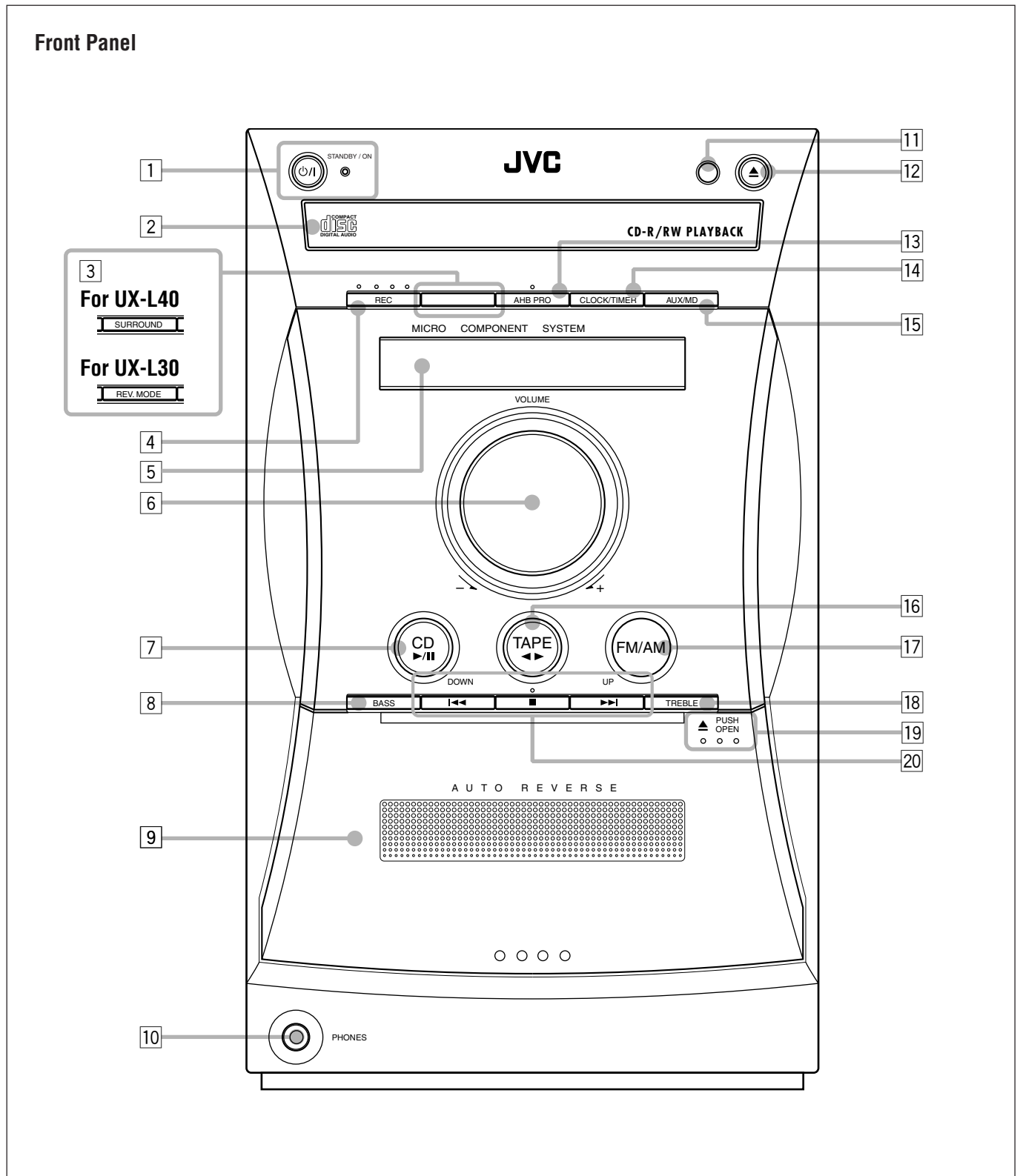

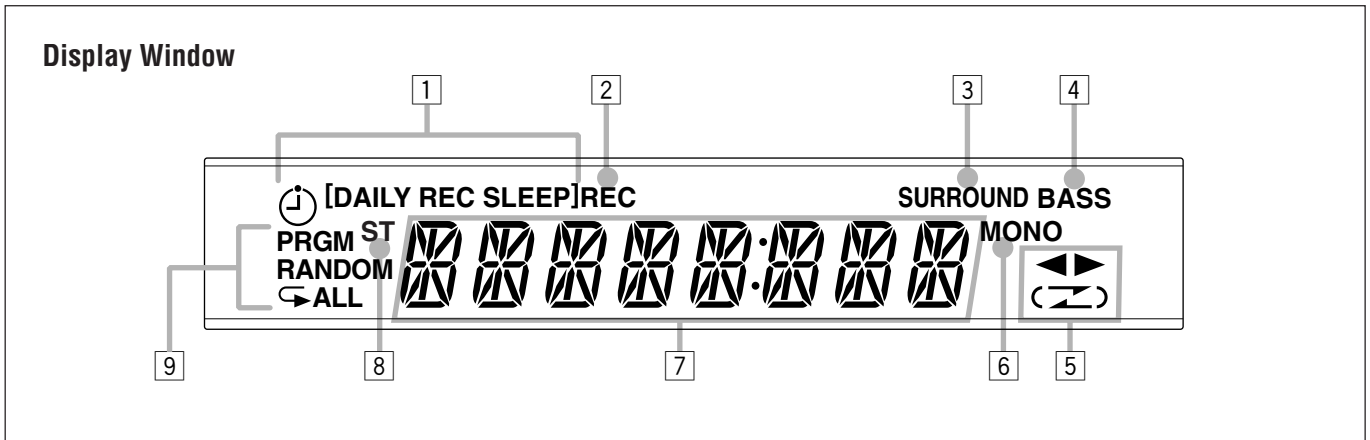

See pages in the parentheses for details.

Front Panel

- 1 STANDBY/ON button and STANDBY/ON lamp (9, 10, 16, 21)
- 2 Disc tray
- 3 For UX-L40: SURROUND button (11)
For UX-L30: REV.MODE (reverse mode) button (17 – 19)
- 4 REC (recording) button (18, 19)
- 5 Display window
- 6 VOLUME + / – control (10)
- 7 CD (play/pause) button (10, 14, 16, 19)
Pressing this button also turns on the unit.
- 8 BASS button (11)
- 9 Cassette holder
- 10 PHONES jack (10)
- 11 Remote sensor
- 12 (disc tray open/close) button (14)
Pressing this button also turns on the unit.
- 13 AHB (Active Hyper Bass) PRO button (11)
- 14 CLOCK/TIMER button (9, 20, 21)
- 15 AUX/MD button (10)
Pressing this button also turns on the unit.
- 16 TAPE (10, 17, 18)
Pressing this button also turns on the unit.
- 17 FM/AM button (10, 12, 13)
Pressing this button also turns on the unit.
- 18 TREBLE button (11)
- 19 PUSH OPEN (cassette holder open) portion (17 – 19)
- 20 Multi operation buttons
 - (reverse skip)/DOWN, (stop)
 - and (forward skip)/UP

Display Window

- 1 Timer indicators
 - (timer), DAILY, REC and SLEEP
- 2 REC (recording) indicator
- 3 SURROUND indicator (ONLY FOR UX-L40)
- 4 BASS indicator
- 5 Tape operation indicators
 - (tape direction) and (reverse mode)
- 6 MONO indicator
- 7 Main display
 - Shows the source name, frequency, etc.
- 8 ST (stereo) indicator
- 9 CD play mode indicators
 - PRGM (program), RANDOM and (repeat one/repeat all)

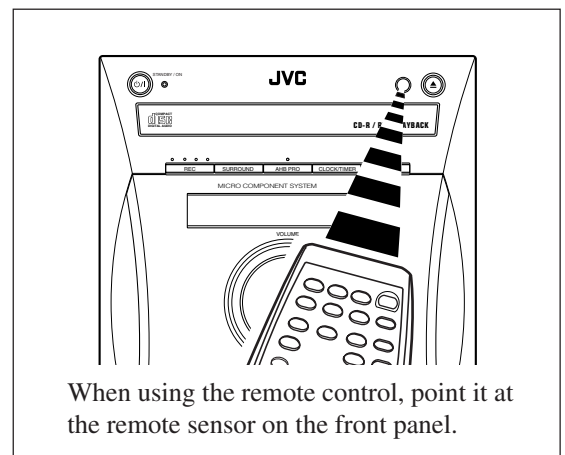

Supplied Accessories

Make sure that you have all the following items. The number in the parentheses indicates the quantity of the pieces supplied.

- AM loop antenna (1)
- FM antenna (1)
- Remote control (1)
- Batteries (2)
- Speaker cords (2) (ONLY FOR UX-L40)
- AC plug adaptor—except for Argentina (1)

If anything is missing, consult your dealer immediately.

Putting the Batteries into the Remote Control

Insert the batteries—R6(SUM-3)/AA(15F)—into the remote control, by matching the polarity (+ and –) on the batteries with the + and – markings on the battery compartment.

When the remote control can no longer operate the unit, replace both batteries at the same time.

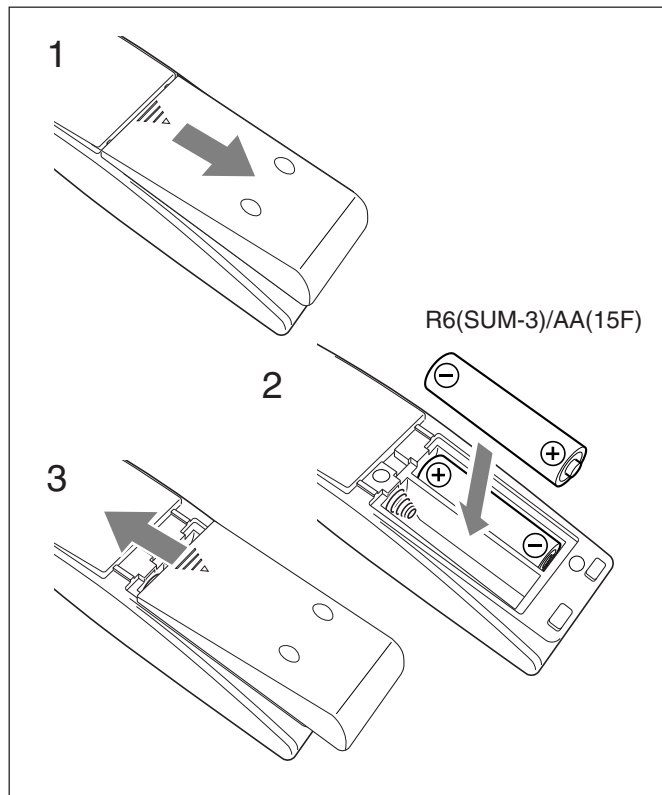

- DO NOT use an old battery together with a new one.
- DO NOT use different types of batteries together.
- DO NOT expose batteries to heat or flame.
- DO NOT leave the batteries in the battery compartment when you are not going to use the remote control for an extended period of time. Otherwise, it will be damaged from battery leakage.

Connecting Antennas

FM antenna

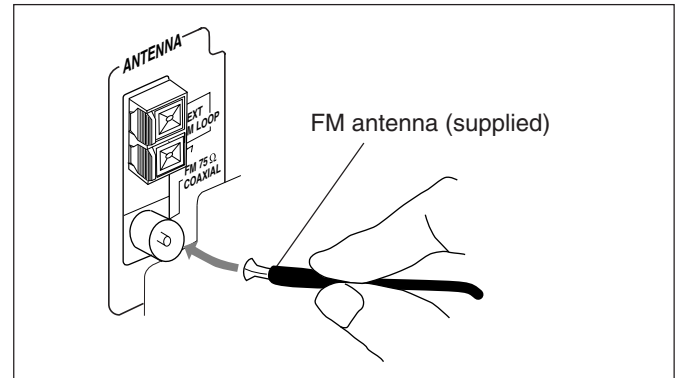

- 1 Attach the FM antenna to the FM 75 Ω COAXIAL terminal.
- 2 Extend the FM antenna.
- 3 Fasten it up in the position which gives you the best reception, then fix it on the wall, etc.



About the supplied FM antenna

The FM antenna supplied with this unit can be used as temporary measure. If reception is poor, you can connect an outdoor FM antenna.

To connect an outdoor FM antenna

Before connecting it, disconnect the supplied FM antenna.

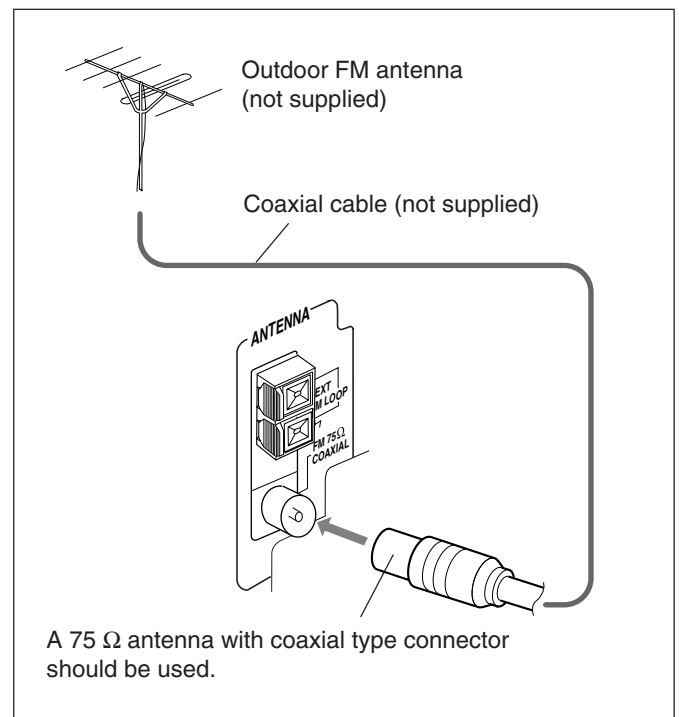

AM antenna

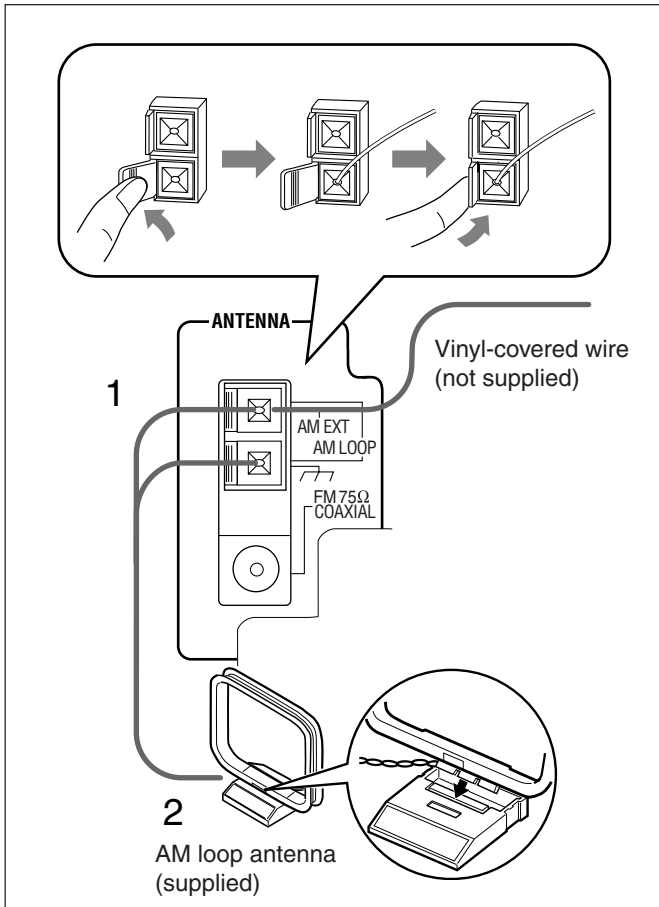

1 Connect the AM loop antenna to the AM LOOP terminals as illustrated.

- If cords are covered with insulation, twist the core of the cord at the end of each cord, then remove the insulation.

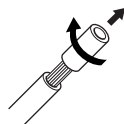

2 Turn the AM loop antenna until you have the best reception.

To connect an outdoor AM antenna

When reception is poor, connect a single vinyl-covered wire to the AM EXT terminal and extend it horizontally. (The AM loop antenna must remain connected.)



For better reception of both FM and AM

- Make sure the antenna conductors do not touch any other terminals and connecting cords.
- Keep the antennas away from metallic parts of the unit, connecting cords, and the AC power cord.

Connecting Speakers

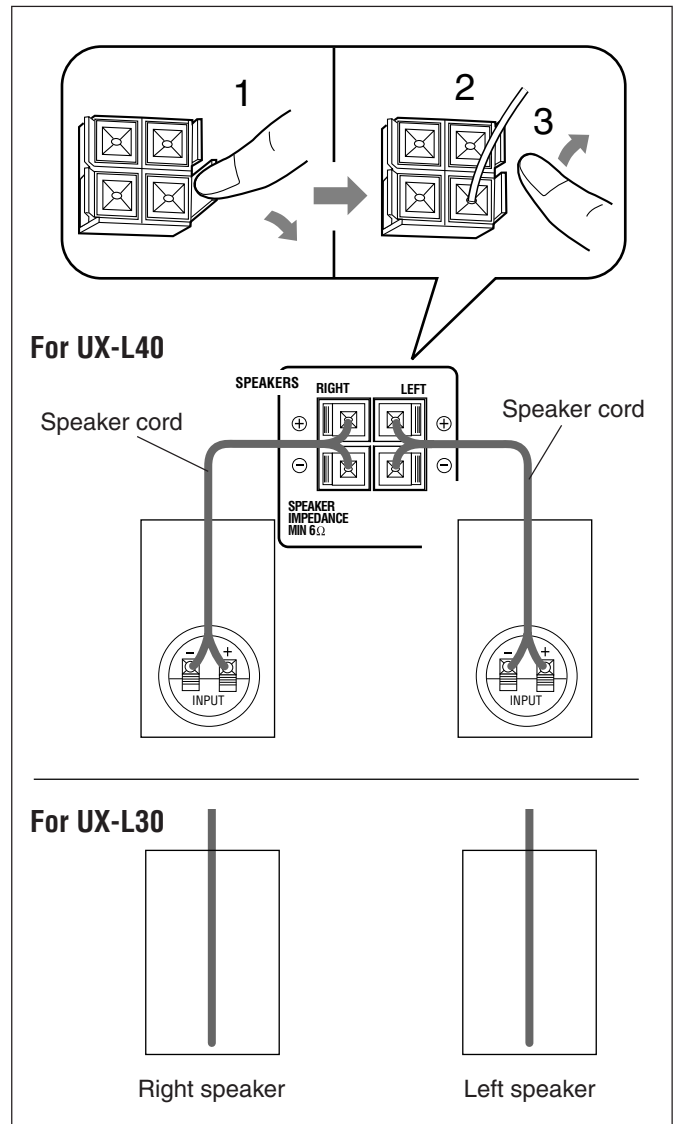

For UX-L40

For UX-L30

1 Press and hold the clamp of the speaker terminal on the rear of the unit.

2 Insert the end of the speaker cord to the terminal.

Match the polarity between the unit and the speaker terminals: (+) to (+) and (-) to (-).

- If cords are covered with insulation, twist the core of the cord at the end of each cord, then remove the insulation.

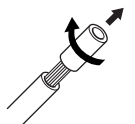

3 Release the finger from the clamp.

IMPORTANT: Use only speakers with the same speaker impedance as indicated by the speaker terminals on the rear of the unit.



To remove the speaker grilles

The speaker grilles are removable.

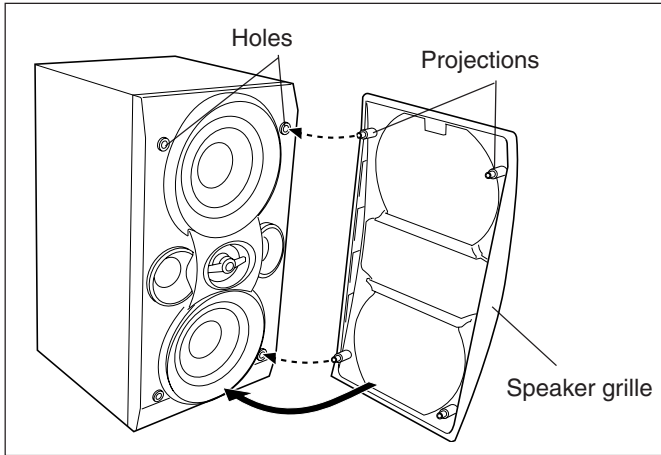

To remove the speaker grille, insert your fingers at the top of the speaker grille, pull towards you. Then pull the bottom towards you.

To attach the speaker grille, put the projections of the speaker grille into the holes of the speaker.

Connecting Other Equipment

You can connect both of the analog and digital equipment.

 • DO NOT connect any equipment while the power is on.
• DO NOT plug in any equipment until all connections are complete.

To connect audio equipment

Be sure that the plugs of the audio cords are colored: White plugs and jacks are for left audio signals, and red ones for right audio signals.

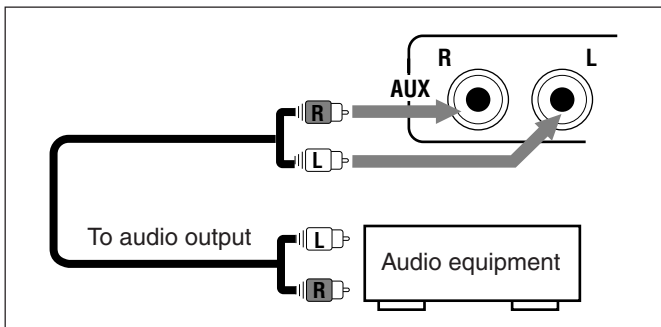

For playing the other equipment through this unit, connect between the audio output jacks on the other equipment and AUX jacks by using audio cords (not supplied).

To connect audio equipment with an optical digital input terminal

You can record CD sound onto the connected digital equipment.

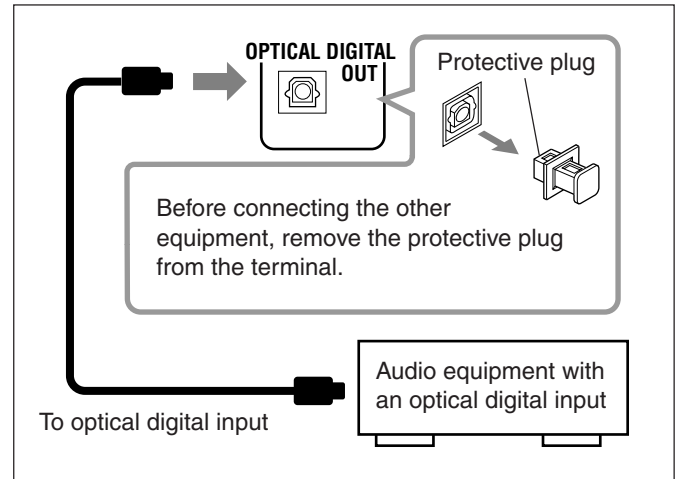

Connect an optical digital cord (not supplied) between the optical digital input terminal on the other equipment and the OPTICAL DIGITAL OUT terminal.

Adjusting the Voltage Selector

Before plugging in the unit, set the correct voltage for your area with the voltage selector on the rear of the unit.

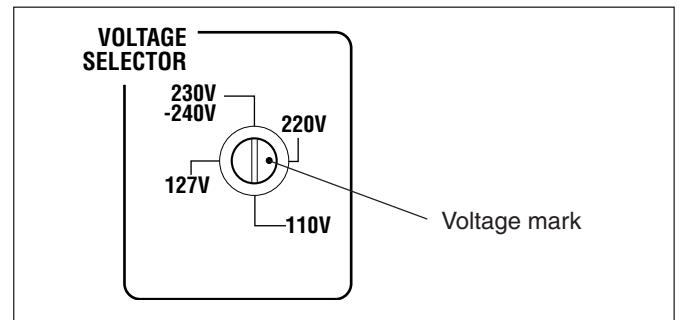

Use a screwdriver to rotate the voltage selector so the voltage number the voltage mark is pointing at is the same as the voltage where you are plugging in the unit. (See the back cover page.)

 DO NOT plug in before setting the voltage selector on the rear of the unit and all connection procedures are complete.

Now, you can plug the AC power cord.

- If the wall outlet does not match the AC plug, use the supplied AC plug adaptor (except for Argentina).

IMPORTANT: Be sure to check all connections to be done before plugging the AC power cord into a wall outlet.

Common Operations

Setting the Clock

Before operating the unit any further, first set the clock built in this unit. When you plug the AC power cord into the wall outlet, “0:00” starts flashing on the display.

You can set the clock whether the unit is on or off.

- There is a time limit in doing the following steps. If the setting is canceled before you finish, start from step 1 again.

1 Press CLOCK/TIMER.

The hour digits start flashing on the display.

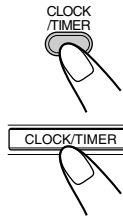

2 Press UP or DOWN to adjust the hour, then press CLOCK/TIMER.

The minute digits start flashing on the display.

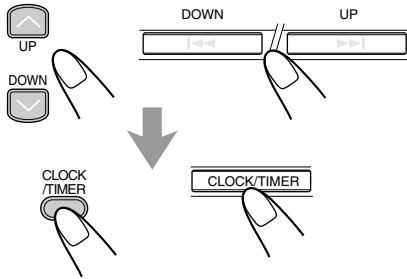

3 Press UP or DOWN to adjust the minute, then press CLOCK/TIMER.

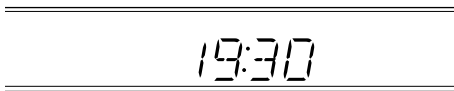

To adjust the clock again

- 1 **Make sure ☹ (timer) indicator is not lit on the display.**
 - If it is lit, press and hold CLOCK/TIMER until it goes off.
- 2 **Press CLOCK/TIMER repeatedly until the unit enters the clock setting mode (the hour digit start flashing on the display).**

First time you press CLOCK/TIMER, the unit enters the timer setting mode.

 - See pages 20 and 21.
- 3 **Repeat steps 2 and 3 of the procedure of “Setting the Clock.”**
- 4 **Press and hold CLOCK/TIMER again so that ☹ (timer) indicator goes off from the display.**

Setting the AM Tuner Interval Spacing

Some countries space AM stations 9 kHz apart, and some countries use 10 kHz spacing.

When shipped, the built-in AM tuner is set to 9 kHz spacing. You can change it to 9 kHz or 10 kHz spacing only while the unit is on standby.

On the unit ONLY:

To select 10 kHz intervals, press STANDBY/ON while holding .

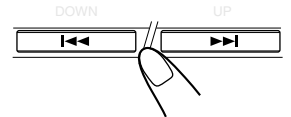

To select 9 kHz intervals, press STANDBY/ON while holding .

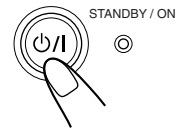

When you change the setting

The preset stations are erased. You will need to preset the stations again. (See page 12.)

To check the clock time during play

On the remote control ONLY:

Press DISPLAY.

- Each time you press the button, the source indication and the clock time alternate on the display.



- **When you unplug the AC power cord or if a power failure occurs**
The clock is reset to “0:00” right away. If this happens, set the clock again.
- **The clock may gain or lose 1 to 2 minutes per month**
If this happens, set the clock again.

Turning On the Power

When you press the play button—CD ►/II, TAPE ◀▶, FM/AM and AUX/MD, the unit automatically turns on and starts playback if the source is ready.

To turn on the unit, press STANDBY/ON .

The STANDBY/ON lamp lights green and “HELLO” appears on the display.

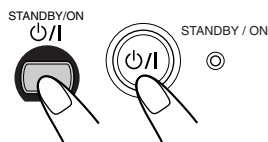

To turn off the unit (on standby), press STANDBY/ON .

again.

The STANDBY/ON lamp lights red and “GOOD BYE” appears on the display.

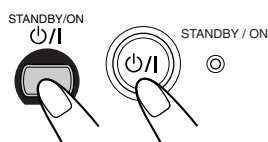

- “0:00” flashes on the display until you set the built-in clock. After setting the clock, the clock time will appear on the display while the unit is on standby.
- A little power is always consumed even while the unit is on standby.

To switch off the power supply completely, unplug the AC power cord from the AC outlet.



When you unplug the AC power cord or if a power failure occurs

The clock is reset to “0:00” right away, while the tuner preset stations (see page 12) will be erased in a few days.

Adjusting the Volume

You can adjust the volume level only while the unit is turned on. The volume level can be adjusted between “VOL MIN” and “VOLUME 1” – “VOLUME 40 (VOL MAX).”

When using the remote control, press VOLUME + to increase the volume or press VOLUME – to decrease it.



When using the unit, turn VOLUME + / – clockwise (+) to increase the volume or counterclockwise (–) to decrease it.

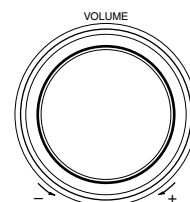

VOLUME 15



For private listening

Connect the headphones to the PHONES jack. No sound comes out of the speakers. Be sure to turn down the volume before connecting or putting on headphones.



DO NOT turn off (on standby) the unit with the volume set to an extremely high level; otherwise, a sudden blast of sound can damage your hearing, speakers and/or headphones when you turn on the unit or start playing any source next time. **REMEMBER** you cannot adjust the volume level while the unit is on standby.

Selecting the Sources and Starting Play

To play back CDs, press CD ►/II. (See pages 14 – 16.)

To play back tapes, press TAPE ◀▶. (See page 17.)

To listen to FM/AM broadcasts, press FM/AM. (See pages 12 – 13.)

To select the external equipment as the source, press AUX/MD.



When you press the play button for a particular source (CD ►/II, TAPE ◀▶, FM/AM and AUX/MD), the unit turns on (and the unit starts playing the source if it is ready).

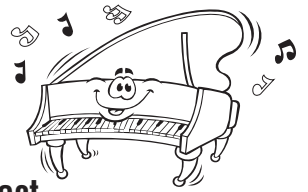

Adjusting the Tone (Bass/Treble)

You can adjust the bass level (low frequency range) and the treble level (high frequency range) within the range of -5 to $+5$. Normally set these to 0 (initial setting at factory).

- This function only affects the playback sound, but does not affect your recording.
- There is a time limit in doing the following steps. If the setting is canceled before you finish, start from step 1 again.

1 Press BASS to adjust the bass level or press TREBLE to adjust the treble level.

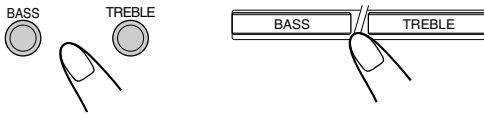

2 Press UP to increase the level or press DOWN to decrease it.

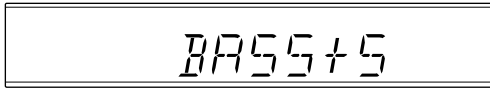

Reinforcing the Bass Sound

You can reinforce the bass sound to maintain rich, full bass at low volume.

- This function only affects the playback sound, but does not affect your recording.

To get the effect, press AHB (Active Hyper Bass) PRO until “AHB 1” or “AHB 2” appears on the display. The BASS indicator also lights up on the display.

- Each time you press the button, the bass sound change as follows:

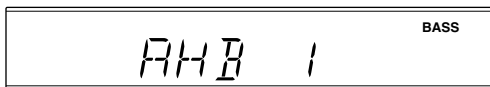
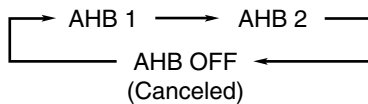

“AHB 2” has much more bass reinforcement effect than “AHB 1.”

To cancel the effect, press AHB PRO until “AHB OFF” appears on the display and the BASS indicator goes off.

Reinforcing the Surround Effect (ONLY FOR UX-L40)

You can reinforce the surround effect.

- This function does not affect
 - your recording.
 - playback sound of the monaural sources.

To get the effect, press SURROUND so that the SURROUND indicator lights up on the display.

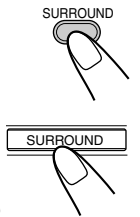

To cancel the effect, press SURROUND again so that the SURROUND indicator goes off.

Selecting the Illumination Brightness

You can change the illumination brightness only while the unit is turned on.

On the remote control ONLY:

To change the brightness, press DIMMER.

- Each time you press the button, the illumination dims and brightens alternately.



Tuning in to a Station

1 Press FM/AM to select the band.

The unit automatically turns on and tunes in to the previously received station (either FM or AM).

- Each time you press the button, the band alternates between FM and AM.

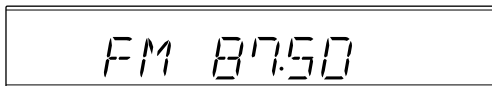

2 Press and hold or for more than 1 second.

The unit starts searching for stations and stops when a station of sufficient signal strength is tuned in.

If a program is broadcast in stereo, the ST (stereo) indicator lights up.

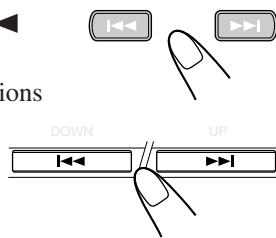

To stop searching, press  or .



When you press  or  briefly and repeatedly

The frequency changes step by step.

To change the FM reception mode

On the remote control ONLY:

When an FM stereo broadcast is hard to receive or noisy, press FM MODE so that the MONO indicator lights up on the display. Reception improves.

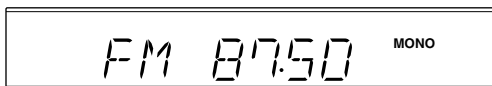
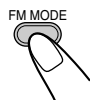

To restore the stereo effect, press FM MODE again so that the MONO indicator goes off. In this stereo mode, you can hear stereo sounds when a program is broadcasted.

Presetting Stations

You can preset 30 FM and 15 AM stations—using either automatic presetting or manual presetting.

In some cases, test frequencies have been already memorized for the tuner since the factory examined the tuner preset function before shipment. This is not a malfunction.

You can preset the stations you want into memory by following the presetting method.

To preset stations automatically—Automatic Presetting

You need to preset stations separately for the FM and AM bands.

On the remote control ONLY:

1 Press FM/AM to select the band you want to preset.

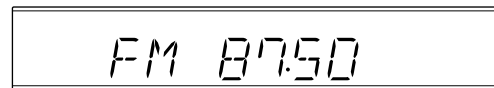

2 Press and hold AUTO PRESET for more than 2 seconds.

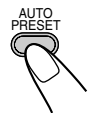

Local stations with strong signals are searched and stored in memory automatically.

When automatic presetting is over, the station stored in preset number 1 is received.

3 Repeat steps 1 and 2 to store stations for the other band.



- **When you cannot automatically store stations you want**
Stations with weak signals cannot be detected with this automatic presetting. To store such a station, use the manual presetting.
- **When you unplug the AC power cord or if a power failure occurs**

Preset stations with the automatic presetting are erased at once. If this happens, preset the stations again.



To preset stations manually—Manual Presetting

You need to preset stations separately for the FM and AM bands.

- There is a time limit in doing the following steps. If the setting is canceled before you finish, start from step 2 again.

On the remote control ONLY:

1 Tune in to the station you want to preset.

- See “Tuning in to a Station” on page 12.

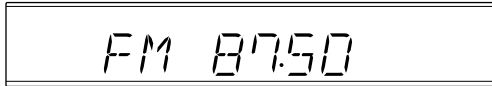

2 Press SET.



3 Press UP or DOWN to select a preset number.

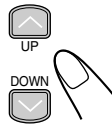
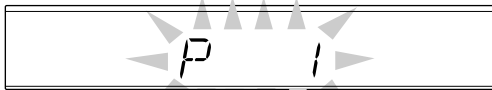

4 Press SET again.



The tuned station in step 1 is stored in the preset number selected in step 3.

- Storing a new station on a used number erases the previously stored one.



When you unplug the AC power cord or if a power failure occurs

The tuner preset stations will be erased in a few days. If this happens, preset the stations again.

Tuning in to a Preset Station

On the remote control ONLY:

1 Press FM/AM to select the band.

The unit automatically turns on and tunes in to the previously received station (either FM or AM).

- Each time you press the button, the band alternates between FM and AM.

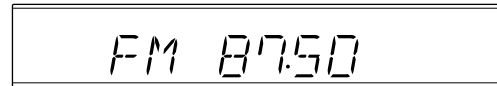

2 Press UP or DOWN to select a preset number.

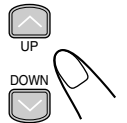

To tune a preset number directly using the number buttons

On the remote control ONLY:

Pressing the number button(s) allows you to select a preset number you want.

- Ex.:
- For preset number 5, press 5.
 - For preset number 15, press +10, then 5.
 - For preset number 20, press +10, then 10.
 - For preset number 30, press +10, +10, then 10.

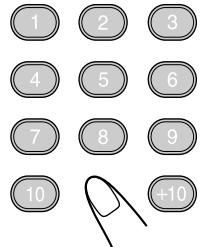

Playing Back CDs (CD/CD-R/CD-RW)

Continued 

This unit has been designed to playback the following CDs:

- CD
- CD-R
- CD-RW

Continued use of irregular shape CDs (heart-shape, octagonal, etc.) can damage the unit.

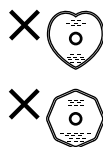

General Notes

In general, you will have the best performance by keeping your CDs and the mechanism clean.

- Store CDs in their cases, and keep them in cabinets or on shelves.
- Keep the unit's disc tray closed when not in use.

When playing a CD-R or CD-RW

User-edited CD-Rs (CD-Recordable) and CD-RWs (CD-ReWritable) can be played back only if they are already "finalized."

- You can play back your original CD-Rs or CD-RWs recorded in music CD format. However, they may not be played back depending on their characteristics or recording conditions.
- Before playing back CD-Rs or CD-RWs, read their instructions or cautions carefully.
- Some CD-Rs or CD-RWs may not be played back on this unit because of their disc characteristics, damage or stain on them, or if the player's lens is dirty.
- CD-RWs may require a longer readout time. This is caused by the fact that the reflectance of CD-RWs is lower than for regular CDs.

Playing Back the Entire CD—Normal Play

1 Press CD on the remote control (or on the unit).

The unit automatically turns on and the disc tray comes out.

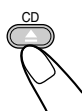

2 Place a disc correctly on the circle of the disc tray, with its label side up.

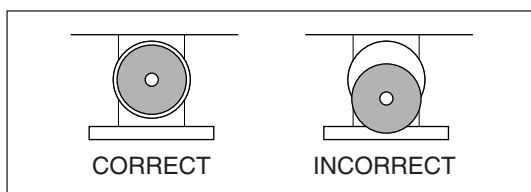

- When using a CD single (8 cm), place it on the inner circle of the disc tray.

3 Press CD .

The disc tray automatically closes and the first track of the CD starts playing.

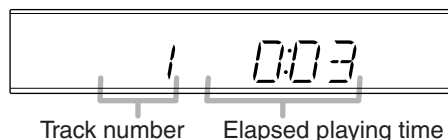

- The CD automatically stops when the last track of the CD has finished playing.

To stop playing, press .

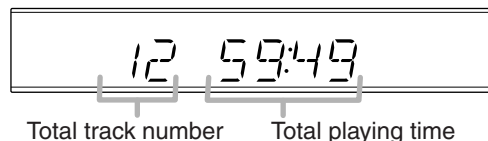

To remove the disc, press  CD on the remote control (or  on the unit).



- **If the CD cannot be read correctly (because it is scratched, for example) or an unreadable CD-R or CD-RW is inserted**
Playback will not start.
- **If no CD is inserted**
"NO DISC" appears on the display.
- **If the loaded CD has more than 21 tracks and you select 21st track or above**
"--:--" appears on the display instead of the playing time.



DO NOT try to open or close the CD tray by hand as it will be damaged.

Basic CD Operations

While playing a CD, you can do the following operations.

To stop playing for a moment

Press CD .

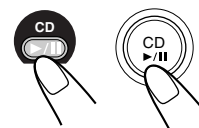

While pausing, the elapsed playing time flashes on the display.



To resume playing, press CD  again.

To go to another track

Press  or  repeatedly.

-  :
Skips to the beginning of the next or succeeding tracks.
-  :
Goes back to the beginning of the current or previous tracks.

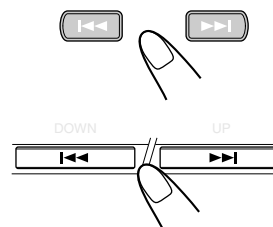

To go to another track directly using the number buttons

On the remote control ONLY:

Pressing the number button(s) allows you to start playing the track number you want.

- Ex.: For track number 5, press 5.
 For track number 15, press +10, then 5.
 For track number 20, press +10, then 10.
 For track number 32, press +10, +10, +10, then 2.

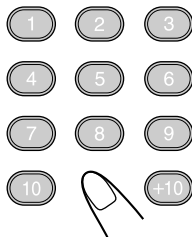

To locate a particular point in a track

During play, press and hold **▶▶** or **◀◀**.

- **▶▶**: Fast-forwards the tracks.
- **◀◀**: Fast-reverses the tracks.

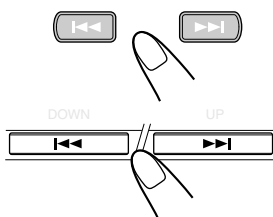

Programming the Playing Order of the Tracks —Program Play

You can arrange the order in which tracks play before you start playing. **You can program up to 20 tracks.**

On the remote control ONLY:

1 Load a CD.

- If the current playing source is not the CD player, press **CD ▶/||**, then **■** before going to the next step.

2 Press PRGM (program).

The PRGM (program) indicator lights up on the display.



- If a program has been stored in memory, the program is called up.

3 Press UP or DOWN to select the track number, then press SET.

- You can select the track number directly using the number buttons. (See “To go to another track directly using the number buttons.”)

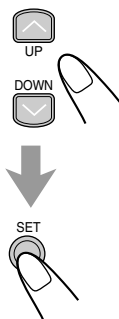
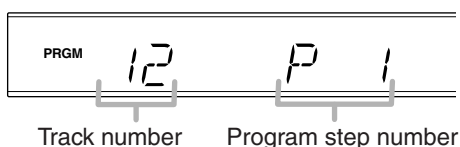

4 Repeat step 3 to program other tracks you want.

5 Press CD ▶/||.

The tracks are played in the order you have programmed.



To stop playing, press **■**.

To exit from Program Play mode, press PRGM before or after playing. The PRGM (program) indicator goes off.

To erase the program, press **■** twice.

- Disc ejection also erases the program.



If you try to program the 21st track “FULL” will appear on the display.

To check the program contents

You can check the program contents by pressing **▶▶** or **◀◀** before or after playback.

- **▶▶**:

To check the contents in the programmed order.

- **◀◀**:

To check the contents in the reverse order.

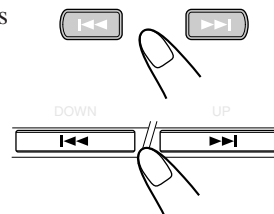

To modify the program

On the remote control ONLY:

Before or after playing, you can erase the last programmed track by pressing CANCEL.

- Each time you press the button, the last programmed track is erased from the program.



To add tracks in the program before playing, simply select the track numbers you want to add by following step 3 of the programming procedure.



Playing at Random—Random Play

The tracks will play in no particular order when you use this mode.

On the remote control ONLY:

1 Load a CD.

- If the current playing source is not the CD player, press CD ►/II, then ■ before going to the next step.

2 Press RANDOM.

The RANDOM indicator lights up on the display and the tracks start playing at random.



3 Press CD ►/II.

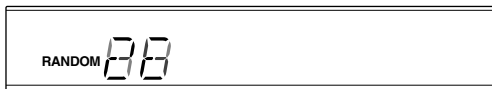

Random Play ends when all the tracks are played once.

To skip the current track, press ►►.

- You cannot go back to the previous track by pressing ◀◀.

To stop playing, press ■.

To exit from Random Play mode, press RANDOM again before or after playing. Random Play mode is canceled and Normal Play resumes.

- The RANDOM indicator goes off.

Repeating Tracks—Repeat Play

You can have all the tracks, the program or individual track currently playing to repeat as many times as you like.

On the remote control ONLY:

To repeat playing, press REPEAT before or during playing.



- Each time you press the button, Repeat Play mode changes as follows, and the following indicator lights up on the display:

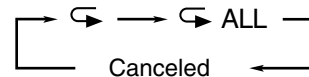

- ◁ : Repeats one track.
- ◁ ALL : In Normal Play mode, repeat all the tracks. In Program Play mode, repeat all the tracks in the program. In Random Play mode, repeats all the tracks in random order.

To stop playing, press ■.

To cancel Repeat Play mode, press REPEAT repeatedly until the repeat indicator goes off.

- Repeat Play mode remains in effect even when you change the play mode.
- In Random Play mode, ◁ cannot be selected. If ◁ has been selected when you press RANDOM, it is canceled.

Prohibiting Disc Ejection—Tray Lock

You can lock the disc tray and prohibit to eject the CD.

- If the current playing source is not the CD player, press CD ►/II, then ■ before performing the procedure below.

On the unit ONLY:

To prohibit disc ejection, press STANDBY/ON ⏻/I while holding ■.

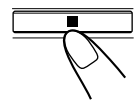

- If the disc tray is opened, close it first.

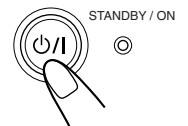

To cancel the prohibition and unlock the CD, press STANDBY/ON ⏻/I while holding ■.

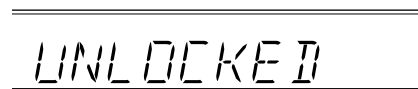

If you try to eject the CD while Tray Lock is in use “LOCKED” appears to inform you that the disc tray is locked.

Playing Back Tapes



You can play back type I, type II, and type IV tapes without changing any settings.

Playing Back a Tape

1 Press **▲ PUSH OPEN** on the unit.

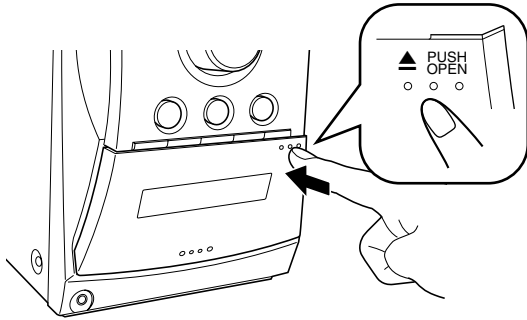

2 Put a cassette in with the exposed part of the tape down.

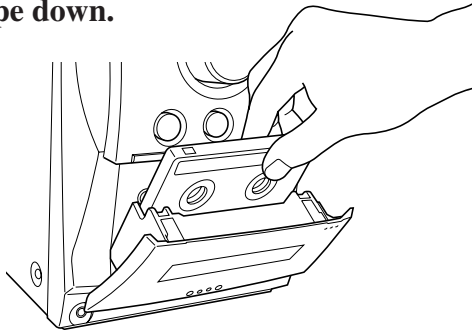

3 Press **▲ PUSH OPEN** again.

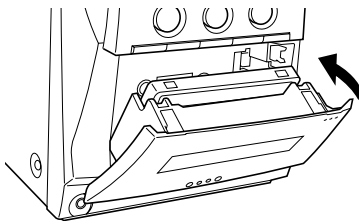



4 Press **TAPE ◀▶**.

The unit automatically turns on and the tape starts playing. The tape direction indicator (▶ or ◀) flashes slowly on the display.

- Each time you press the button, the tape direction changes.

- ▶ : plays the front side.
- ◀ : plays the reverse side.



When the tape plays to the end, the deck automatically stops if the reverse mode is set to  or . (See “To play both sides—Reverse Mode.”)

To stop playing, press **■**.

To fast-wind to the left or to the right, press **▶▶** or **◀◀** while the tape is not running.

The tape direction indicator (▶ or ◀) starts flashing quickly on the display.

To remove the cassette, press **▲ PUSH OPEN** on the unit.

To play both sides—Reverse Mode

You can set the deck to play just one side of a tape, both sides once, or both sides continuously.

Press **REV.MODE**.

- Each time you press the button, reverse mode changes as follows:

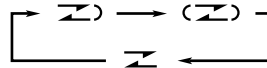

 : The deck automatically stops after playing both sides of the tape. Stops when playback in the ◀ direction is finished.

 : The deck continues to play both sides of the tape until **■** is pressed.

 : The deck automatically stops after playing one side of the tape.

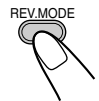

REV.MODE

On the unit
(only for UX-L30)



The use of the C-120 or thinner tape is not recommended, since characteristic deterioration may occur and this tape easily jams in the pinch-rollers and the capstans.



If no cassette is inserted

“NO TAPE” appears on the display.

IMPORTANT:

- It may be unlawful to record or play back copyrighted material without the consent of the copyright owner.
- The recording level is automatically set correctly, so it is not affected by the other sound settings. Thus, during recording you can adjust the sound you are actually listening to without affecting the recording level.
- If recordings you have made have excessive noise or static, the unit may be too close to a TV. Increase the distance between the TV and the unit.
- You can use type I tape for recording.

To protect your recording

Cassettes have two small tabs on the back to protect from unexpected erasure or re-recording.

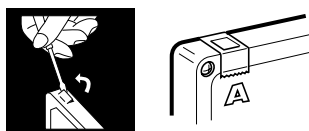

To protect your recording, remove these tabs.

To re-record on a protected tape, cover the holes with adhesive tape.

To keep the best recording and playback sound quality

If the heads, capstans, and pinch rollers of the cassette decks become dirty, the following will occur:

- Impaired sound quality
- Discontinuous sound
- Fading
- Incomplete erasure
- Difficulty in recording

To clean the heads, capstans, and pinch rollers

Use a cotton swab moistened with alcohol.

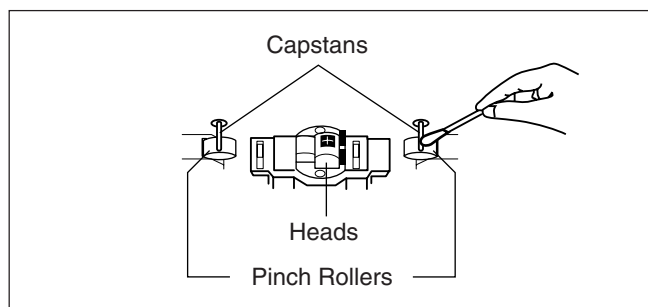

To demagnetize the heads

Turn off the unit, and use a head demagnetizer (available at electronics and audio shops).



At the start and end of cassette tapes

There is leader tape which cannot be recorded onto. Thus, when recording CDs or radio broadcasts, wind the leader tape first to ensure that the recording will be made without any music part lost.

Recording on a Tape

On the unit ONLY:

- 1 Put a recordable cassette in with the exposed part of the tape down.

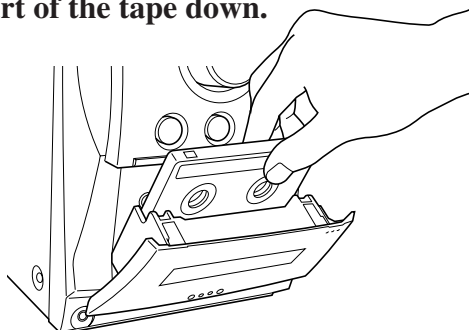

- 2 Close the cassette holder gently and check the recording direction for the tape.

- If the tape direction is not correct, press TAPE ◀▶ twice then ■ to change the tape direction.
- If you want to record on both sides of a tape, see “To record on both sides—Reverse Mode.”

- 3 Start playing the source—FM, AM or auxiliary equipment connected to AUX jacks.

- When the source is CD, see “CD Direct Recording” on page 19.

- 4 Press REC (recording).

The REC (recording) indicator lights up on the display and recording starts.

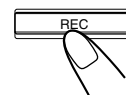

To stop recording, press ■.

The tape stops after 4 seconds.

To remove the cassette, press ▲ PUSH OPEN on the unit.

To record on both sides—Reverse Mode

Press REV.MODE (reverse mode) until the ⚡) indicator is lit.

- When using the Reverse Mode for recording, start recording in the forward (▶) direction first. Otherwise, recording will stop when recording is done only on one side (reverse) of the tape.



On the unit (only for UX-L30)



CD Direct Recording

Everything on the CD goes onto the tape in the order it is on the CD, or according to the order you have made for Program Play.

On the unit ONLY:

- 1 Put a recordable cassette in with the exposed part of the tape down.

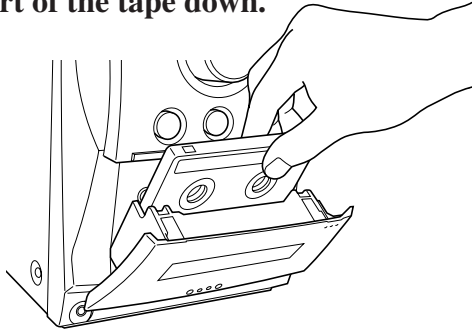

- 2 Load a CD.

- If the current playing source is not the CD player, press CD ►/||, then ■ before going to the next step.
 - If you do not want pauses of about 4 seconds recorded between selections, press CD ►/|| twice. Otherwise, non-recorded pause will be automatically recorded between selections.
- If you want to record on both sides of a tape, see “To record on both sides—Reverse Mode.”

- 3 Press REC (recording).

The REC (recording) indicator lights up on the display and recording starts. After recording, the CD player and cassette deck automatically stop.

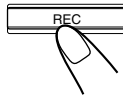

To stop while recording, press ■.

The tape stops after 4 seconds.

To remove the cassette, press ▲ PUSH OPEN on the unit.

To record on both sides—Reverse Mode

Press REV.MODE (reverse mode) until the ◀▶ indicator is lit.

- When using the Reverse Mode for CD Direct Recording, start recording in the forward (▶) direction first. When the tape reaches its end while recording a song in the forward direction (▶), the last song will be re-recorded at the beginning of the reverse side (◀).

If you start recording on the reverse side (◀), recording will stop when recording is done only on one side (reverse) of the tape.

REV.MODE



REV.MODE



On the unit
(only for UX-L30)

One Track Recording

This recording method is convenient when you record tracks while playing the CD. You can only record your favorite songs on the tape.

On the unit ONLY:

- 1 Put a recordable cassette in with the exposed part of the tape down.

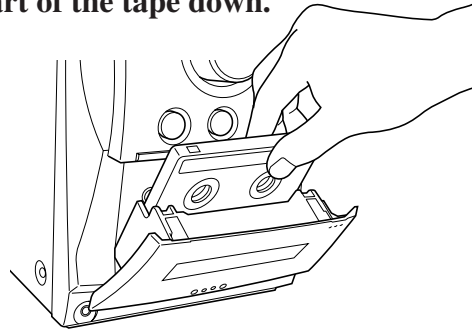

- 2 Play the track on the CD you wish to record.

- 3 Press REC (recording).

The CD player returns to the beginning of that track and the track is recorded on the tape.

After recording, the CD player and cassette deck automatically stop.

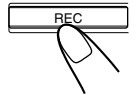

- 4 Repeat steps 2 and 3 to record other tracks you want.

To stop while recording, press ■.

The tape stops after 4 seconds.

To remove the cassette, press ▲ PUSH OPEN on the unit.



When making Sleep Timer settings while doing CD Direct recording

Set enough time to allow for the CD to finish playing; otherwise the power will go off before recording is completed.

There are three timers available—Daily Timer, Recording Timer and Sleep Timer.
Before using the timers, you need to set the clock built in the unit (see page 9).

Using Daily Timer and Recording Timer

You can set the timer whether the unit is on or off.

When the on-time comes, the unit automatically turns on (⊕ (timer) indicator flashes just before the on-time, and continues flashing while the timer is operating). Then, when the off-time comes, the unit automatically turns off (on standby).

The timer setting remains in memory until you change it.

- When the DAILY indicator is lit on the display, the timer acts as the Daily Timer. Once the Daily Timer has been set, it will be activated at the same time everyday until the timer is turned off.
- When the REC indicator is lit on the display, the timer acts as the Recording Timer. After the Recording Timer has been performed, the details of the setting remain stored but the timer is turned off.

Before you start...

When using “TUNER” as the source to play, make sure to select the desired station before turning off the power.

- There is a time limit in doing the following steps. If the setting is canceled before you finish, start from step 1 again.

1 Press CLOCK/TIMER.

⊕ (timer) indicator lights up, and the timer mode indicator (DAILY or REC) and the current on-time flash on the display.
The unit enters on-time setting mode.

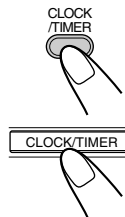

2 Set the on-time when you want the unit to turn on.

- 1) Press UP or DOWN to set the hour, then press CLOCK/TIMER.
- 2) Press UP or DOWN to set the minute, then press CLOCK/TIMER.

The unit enters off-time setting mode.

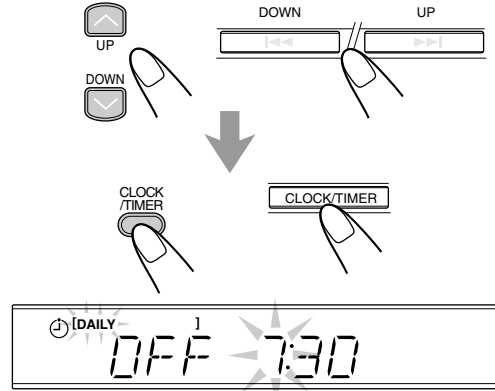

3 Set the off-time when you want the unit to turn off (on standby).

- 1) Press UP or DOWN to set the hour, then press CLOCK/TIMER.
- 2) Press UP or DOWN to set the minute, then press CLOCK/TIMER.

The unit enters source selecting mode.

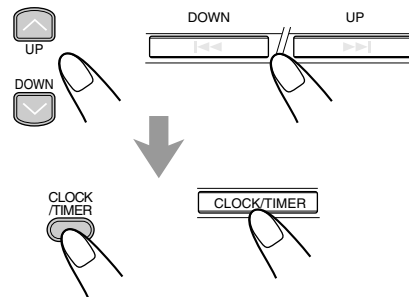

4 Press UP or DOWN to select the timer mode (Daily Timer or Recording Timer) and the source to play, then press CLOCK/TIMER.

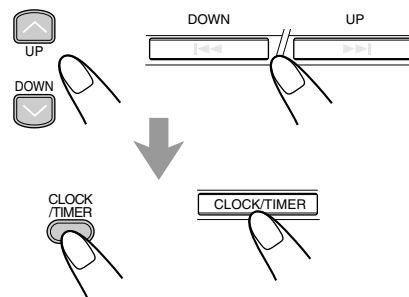



- Each time you press these buttons, the timer mode and the source change as follows:

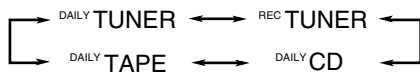

- DAILY TUNER** : tunes in to the last station you were listening to. (Daily Timer)
- REC TUNER** : records the last station you were listening to. (Recording Timer)
- Put a recordable cassette into the deck.
- DAILY CD** : plays a CD. (Daily Timer)
- Load a CD.
- DAILY TAPE** : plays a tape. (Daily Timer)
- Make sure that the tape direction is correct.

5 Press UP or DOWN to set the volume level, then press CLOCK/TIMER.

- You can select the volume level (“VOLUME --” and “VOLUME 0” to “VOLUME 40”).
If you select “VOLUME --,” the volume is set to the last level when the unit has been turned off.
- To turn off the volume while the Recording Timer (REC TUNER) is working,** set the volume level “VOLUME 0.”

The unit enters the clock setting mode.

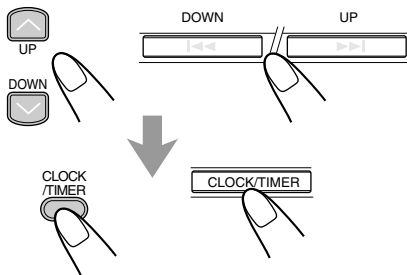



6 Adjust the clock.

- See “Setting the Clock” on page 9.

7 Press STANDBY/ON to turn off the unit (on standby) if you have set the timer with the unit turned on.

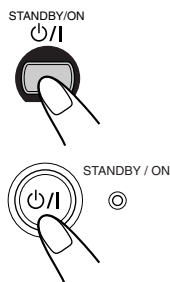
- When the timer turns on the unit,  (timer) indicator and the selected timer mode indicator (DAILY or REC) start flashing.



To cancel the setting, press and hold CLOCK/TIMER until  (timer) indicator goes off from the display.



- If the unit is turned on when the timer-on time comes**
Timer does not work.
- When you unplug the AC power cord or if a power failure occurs**
The timer will be canceled. You need to set the clock first, then the timer again.

Using Sleep Timer

With Sleep Timer, you can fall asleep to music.
You can set Sleep Timer when the unit is turned on.

How Sleep Timer actually works

The unit automatically turns off after the specified time length passes.

On the remote control ONLY:

1 Press SLEEP.

The time length until the shut-off time appears and the SLEEP indicator lights up on the display.



- Each time you press the button, the time length changes as follows:

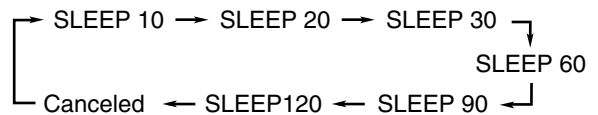

2 Wait for about 5 seconds after specifying the time length.

To check the remaining time until the shut-off time, press SLEEP once so that the remaining time until the shut-off time appears for about 5 seconds.

To change the shut-off time, press SLEEP repeatedly until the desired time length appears on the display.

To cancel the setting, press SLEEP repeatedly until the SLEEP indicator goes off.

- Sleep Timer is also canceled when you turn off the unit.



- If you set the Sleep Timer after Daily Timer starts playing the selected source**
Daily Timer is canceled.
- If you set the Sleep Timer after Recording Timer starts recording**
Recording Timer is canceled, but recording continues until Sleep Timer shuts off the power.

Troubleshooting



If you are having a problem with your unit, check this list for a possible solution before calling for service. If you cannot solve the problem from the hints given here, or the unit has been physically damaged, call a qualified person, such as your dealer, for service.

Symptom	Cause	Action
No sound is heard.	<ul style="list-style-type: none"> • Connections are incorrect or loose. • Headphones are connected. 	<ul style="list-style-type: none"> • Check all connections and make corrections. (See pages 6 to 8.) • Disconnect the headphones.
Hard to listen to broadcasts because of noise.	<ul style="list-style-type: none"> • Antennas are disconnected. • The AM loop antenna is too close to the unit. • The FM antenna is not properly extended and positioned. 	<ul style="list-style-type: none"> • Reconnect the antennas correctly and securely. • Change the position and direction of the AM loop antenna. • Extend the FM antenna at the best position.
The disc tray does not open or close.	The AC power cord is not plugged in.	Plug the AC power cord.
The disc does not play.	The disc is placed upside down.	Place the disc with the label side up.
The disc sound is discontinuous.	The disc is scratched or dirty.	Clean or replace the disc. (See page 23.)
The cassette holder cannot be opened.	Power supply from the AC power cord has been cut off while the tape was running.	Turn on the unit.
Impossible to record.	Small tabs on the back of the cassette are removed.	Cover the holes with adhesive tape.
Operations are disabled.	The built-in microprocessor may malfunction due to external electrical interference.	Unplug the AC power cord and then plug it back in.
Unable to operate the unit from the remote control.	<ul style="list-style-type: none"> • The path between the remote control and the remote sensor on the unit is blocked. • The batteries are exhausted. 	<ul style="list-style-type: none"> • Remove the obstruction. • Replace the batteries.

Maintenance

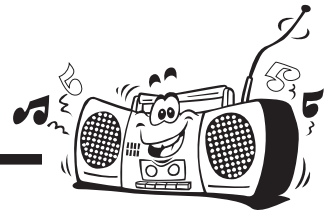

To get the best performance of the unit, keep your discs, tapes, and mechanism clean.

Handling discs



- Remove the disc from its case by holding it at the edge while pressing the center hole lightly.
- Do not touch the shiny surface of the disc, or bend the disc.
- Put the disc back in its case after use to prevent warping.

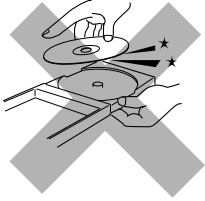

- Be careful not to scratch the surface of the disc when placing it back in its case.
- Avoid exposure to direct sunlight, temperature extremes, and moisture.



To clean the disc

Wipe the disc with a soft cloth in a straight line from center to edge.

DO NOT use any solvent—such as conventional record cleaner, spray, thinner, or benzine—to clean the disc.

Cleaning the unit

Stains on the unit

- Should be wiped off with a soft cloth. If the unit is heavily stained, wipe it with a cloth soaked in water-diluted neutral detergent and wrung well, then wipe clean with a dry cloth.
- **Since the unit may deteriorate in quality, become damaged or get its paint peeled off, be careful about the followings.**
 - DO NOT wipe it with a hard cloth.
 - DO NOT wipe it strong.
 - DO NOT wipe it with thinner or benzine.
 - DO NOT apply any volatile substance such as insecticides to it.
 - DO NOT allow any rubber or plastic to remain in contact with it for a long time.

Handling cassette tapes

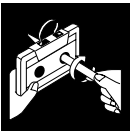

- If the tape is loose in its cassette, take up the slack by inserting a pencil in one of the reels and rotating.
- If the tape is loose, it may get stretched, cut, or caught in the cassette.



- Be careful not to touch the tape surface.



- Avoid the following places to store the tape:
 - In dusty places
 - In direct sunlight or heat
 - In moist areas
 - On a TV or speaker
 - Near a magnet

Specifications

Design and specifications are subject to change without notice.

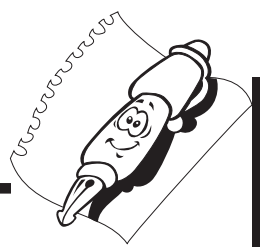

UX-L40 (CA-UXL40 and SP-UXL40)

Amplifier

Output Power:
120 W (60 W + 60 W) at 6 Ω (MAX.)
100 W (50 W + 50 W) at 6 Ω (10% THD)
Audio input sensitivity/Impedance (at 1 kHz)
AUX: 400 mV/48 kΩ
Digital output—OPTICAL DIGITAL OUT
Signal wave length: 660 nm
Output level: -21 dBm to -15 dBm
Speakers/Impedance: 6 Ω - 16 Ω

Tuner

FM tuning range: 87.50 MHz - 108.00 MHz
AM tuning range:
At 9 kHz intervals: 531 kHz - 1 710 kHz
At 10 kHz intervals: 530 kHz - 1 710 kHz

CD player

Dynamic range: 85 dB
Signal-to-noise ratio: 90 dB
Wow and flutter: Immeasurable

Cassette deck

Frequency response:
Normal (type I): 60 Hz - 14 000 Hz
Wow and flutter: 0.15% (WRMS)

General

Power requirement:
AC 110 V/ 127 V/ 220 V/ 230 V - 240 V \sim , adjustable
with the voltage selector, 50 Hz/60 Hz
Power consumption: 90 W (at operation)
7.2 W (on standby)
Dimensions (approx.):
170 mm x 286 mm x 319.5 mm (W/H/D)
Mass (approx.): 12.7 kg

Supplied Accessories

See page 6.

Speaker

Speaker units: Woofer: 10.0 cm cone x 2
Tweeter: 4.0 cm cone x 1
Impedance: Main speaker: 6 Ω
Dimensions (approx.):
175 mm x 320 mm x 229 mm (W/H/D)
Mass (approx.): 3.0 kg each

UX-L30 (CA-UXL30 and SP-UXL30)

Amplifier

Output Power:
120 W (60 W + 60 W) at 6 Ω (MAX.)
100 W (50 W + 50 W) at 6 Ω (10% THD)
Audio input sensitivity/Impedance (at 1 kHz)
AUX: 400 mV/48 kΩ
Digital output—OPTICAL DIGITAL OUT
Signal wave length: 660 nm
Output level: -21 dBm to -15 dBm
Speakers/Impedance: 6 Ω - 16 Ω

Tuner

FM tuning range: 87.50 MHz - 108.00 MHz
AM tuning range:
At 9 kHz intervals: 531 kHz - 1 710 kHz
At 10 kHz intervals: 530 kHz - 1 710 kHz

CD player

Dynamic range: 85 dB
Signal-to-noise ratio: 90 dB
Wow and flutter: Immeasurable

Cassette deck

Frequency response:
Normal (type I): 60 Hz - 14 000 Hz
Wow and flutter: 0.15% (WRMS)

General

Power requirement:
AC 110 V/ 127 V/ 220 V/ 230 V - 240 V \sim , adjustable
with the voltage selector, 50 Hz/60 Hz
Power consumption: 90 W (at operation)
7.2 W (on standby)
Dimensions (approx.):
170 mm x 286 mm x 319.5 mm (W/H/D)
Mass (approx.): 12.7 kg

Supplied Accessories

See page 6.

Speaker

Speaker units: Woofer: 12.0 cm cone x 1
Tweeter: 4.0 cm cone x 1
Impedance: Main speaker: 6 Ω
Dimensions (approx.):
160 mm x 285 mm x 186.5 mm (W/H/D)
Mass (approx.): 2.4 kg each

Mains (AC) Line Instruction (not applicable for Europe, U.S.A., Canada, Australia, and U.K.)

Instrucción sobre la línea de la red (CA) (no aplicable para Europa, EE.UU., Canadá, Australia, ni el Grã-Bretanha)

Instrução sobre a tensão da rede eléctrica (CA) (não aplicável para a Europa, os E.U.A., o Canadá, a Austrália e o Reino Unido)

VOLTAGE SELECTOR

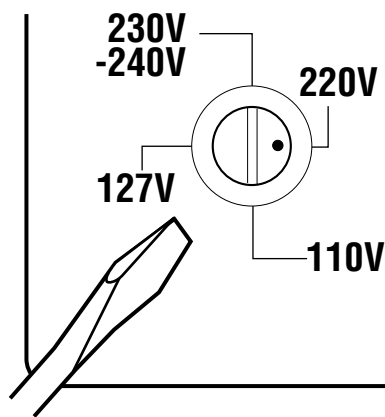

IMPORTANT for mains (AC) line

BEFORE PLUGGING IN, do check that your mains (AC) line voltage corresponds with the position of the voltage selector switch provided on the outside of this equipment and, if different, reset the voltage selector switch, to prevent from a damage or risk of fire/electric shock.

IMPORTANTE para la línea de la red (CA)

ANTES DE ENCHUFAR EL EQUIPO, compruebe si la tensión de la línea de la red (CA) corresponde con la posición del selector de tensión situado en la parte exterior del equipo, y si es diferente, reajuste el selector de tensión para evitar el riesgo de incendios/descargas eléctricas.

IMPORTANTE para a ligação à tensão da rede (CA)

ANTES DE LIGAR O APARELHO A UMA TOMADA DA REDE, verifique se a tensão da rede CA corresponde à posição do seletor de voltagem localizado na parte externa deste equipamento. Caso não corresponda, reajuste o seletor de voltagem a fim de evitar avarias ou riscos de incêndio e choque elétrico.

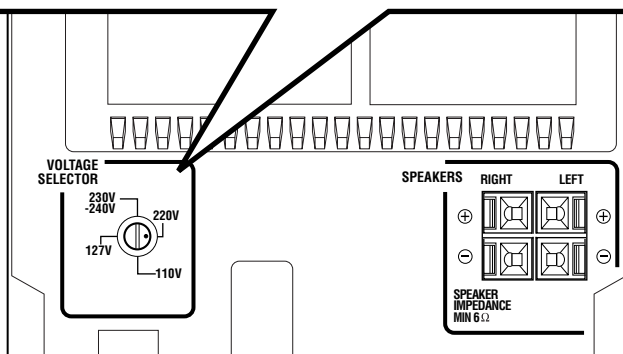

JVC

VICTOR COMPANY OF JAPAN, LIMITED